



JRC SCIENTIFIC AND POLICY REPORTS

Information Collection in Energy Efficiency for Fisheries (ICEEF2011)

Edited by

Antonello Sala, Emilio Notti (CNR, ISMAR)
Jann Martinsohn, Dimitrios Damalas (JRC)

This report has been prepared under contract ICEEF Service Contract Nr. 256660
by CNR-ISMAR, Ancona (Italy)

Legal Notice

Neither the European Commission nor any person acting on behalf of the Commission is responsible for the use which might be made of this publication.

This report does not necessarily reflect the view of the European Commission and in no way anticipates the Commission's future policy in this area.

Europe Direct is a service to help you find answers to your questions about the European Union

Freephone number (*): 00 800 6 7 8 9 10 11

(*): Certain mobile telephone operators do not allow access to 00 800 numbers or these calls may be billed.

A great deal of additional information on the European Union is available on the Internet.

It can be accessed through the Europa server <http://europa.eu/>

Luxembourg: Publications Office of the European Union, 2012

© European Union, 2012

Reproduction is authorised provided the source is acknowledged

Printed in Italy



CNR-ISMAR, Ancona (Italy)

Information Collection in Energy Efficiency for Fisheries (ICEEF2011)

Final Report

Project Responsible: Antonello Sala

07/02/2012

Disclaimer

This report has been prepared under contract ICEEF Service Contract Nr. 256660 by CNR-ISMAR, Ancona (Italy). It does not necessarily reflect the view of the European Commission and in no way anticipates the Commission's future policy in this area.

LIST OF CO-AUTHORS (ALPHABETIC ORDER)

Name	Member State	Organisation
O'NEILL, Finbarry F. G.	Scotland (UK)	MARLAB
PRIOUR, Daniel	France	IFREMER
SALZ, Pavel	The Netherlands	FRAMIAN
STEELE, Jeff	USA	GLOBAL MARINE CONSULTING INC.

FOREWORD

Introduction to ICEEF project

The Joint Research Centre (JRC) has developed a pilot web-site on energy efficiency in fisheries, available at <https://energyefficiency-fisheries.jrc.ec.europa.eu>. The site is accessible directly through the Europe web-site of DG MARE for fisheries.

The pilot web-site includes reference documents and studies related to energy savings in fisheries, general information on research and funding opportunities and links to relevant EU projects, EU legislation and events, among others.

As the Commission is planning to update, further develop and maintain this web site, CNR – ISMAR Institute was charged to collect information and material to update and develop further this web-site. Some scientific experts have been involved relating to their specific knowledge and they reflect the following disciplines needed to accomplish its tasks, on the basis of their expertise in fisheries. Some specialized websites have been also monitored as well as government agencies in EU27 for funding such initiatives (national level) and also into University departments and research centers in the EU and world-wide working in relevant topics. Furthermore, a terminology glossary in many EU languages was completed.

ICEEF 2011

On the basis of the ICEEF 2010 experience, during ICEEF 2011 further information has been collected in relation to the state of the art of fisheries technology. Most of the material collected has been obtained by exhibitions and conferences. During these visits it has been possible also to promote the website. A rising up of web site contacts has been noticed, mainly because of the interest of people for an opportunity for their activity to find an easy way to share information. Most part of the work has been organized to be shared in three upload. Contemporary a continuous streaming of information from JRC and CNR – ISMAR was maintained.

One of the main goals of this second edition of the ICEEF project has been an useful way to share information collected. So CNR – ISMAR has developed an internal web site for a free access to visit reports and other material and services.

Furthermore a questionnaire was created to test the point of view of different people involved in fisheries sector. Results of the questionnaire could be used to define a profile and to suggest how to improve actions by EU, in order to match needs and interests of fishermen, as well as any other stakeholders.

Final Report

Contents

1. Visit reports.....	9
1.1 International Fishing Fair 2011 – Ancona, Italy – Visit report.....	9
Hybrid Propulsion system by Pronaves	9
Grilli sas.....	11
Ecofishman meeting	12
Technical innovations in fisheries.....	13
1.2 IMAM 2011 –Genoa, Italy – Visit report – Fishing Section	15
Carbon footprint and energy use of Norwegian fisheries and seafood products.....	18
Fuel efficiency in trawlers under different fishing tactics using a consumption model and VMS data: a case-study for the Portuguese fleet.....	27
Towards sustainable Baltic herring fishery: trawls vs. pound nets	33
1.3 IMAM 2011 –Genoa, Italy – Visit report – Engineering Section	36
A mathematical model of the propeller pitch change mechanism for the marine propulsion control design.....	36
Latest experiences with contracted and loaded tip (clt) propellers.....	36
Endplate effect propellers: a numerical overview	39
One solution for all emission challenges? an overview about the reduction of exhaust emissions from shipping	39
Evaluation of ship efficiency indexes.....	40
A new approach in engine-propeller matching.....	40
Numerical and experimental optimization of a cp propeller at different pitch settings.....	41
Combustion chamber of the diesel engine—theory and numerical simulation	41
Evaluation of ignition and combustion quality of different formulations of heavy fuel marine oil by laboratory and engine test	42
3D measurements of the effective propeller jet flow behind the rudder	42
A new logic for controllable pitch propeller management	42
Exhaust gas waste heat recovery in marine propulsion plants	43

Mean value modeling and model predictive control of turbocharged diesel engine airpath.....	43
1.4 IceFish 2011 –Reykjavik, Iceland	44
LUMINELL AS – Powerful LED Floodlight	44
IBERCISA – Electric winches	44
VAN BEELEN – Dyneema.....	47
POLY – ICE TRAWL DOORS - pelagic trawl doors	48
DYNEX WARPS.....	48
1.5 DanFish 2011 –Aalborg, Denmark.....	50
ROLLS ROYCE.....	50
MAN	53
GENERGI Hydraulic driven generators.....	54
DESMI.....	56
Energy Reductions in Fishing Vessels	57
Optimizing fuel consumption	62
BEEP – A demonstration project.....	67
1.6 DeMaT’ 2011 –Split	69
About “DeMaT’2011 – Methods for the Development and Evaluation of Maritime Technologies”	69
Modeling gear seabed interaction during demersal trawling - design study.....	69
Contact forces between seabed and fishing gear components	72
Hydropêche: experimental and numerical developments for fishing devices optimisation.....	78
New hybrid diesel electric propulsion system for trawlers.....	79
1.7 French Fisheries.....	84
Project synthesis	84
Visit of SHIPSTUDIO	90
1.8 Scottish Fisheries	94
Scotnet International – Gears of reduced drag and Selective fishing gears. Fraserburgh, Scotland.....	94
Gamrie Bay Prawn Trawls – Selective fishing gears. Gardenstown, Aberdeenshire, Scotland.	94

Faithlie Trawls – Gears of reduced drag and Selective fishing gears Fraserburgh, Scotland.	95
School of Engineering, Aberdeen University, Scotland.	95
The interaction between towed demersal gears and seabed sediment.....	96
Hydrodynamics of fishing gear: An experimental study.....	97
Sail Line Fish Ltd. Wind assisted fishing.	98
The Sail Line Fish Project.....	100
1.9 US fisheries	101
Introduction	101
Fuel Quality.....	102
By-Pass Oil Filtration	105
Bottom Coatings	108
Bulbous Bows.....	109
Kort Nozzles	112
Hydrogen Supplement Fuel	113
Emulsified Diesel Fuel	115
Fuel Reduction Case Study.....	116
Opportunities.....	119
2. Material and information collected.....	120
List of Associations.....	120
2.1 News	122
2.2 Events	127
3. ISMAR – CNR Web page.....	130
3.1 Topic specifications	130
3.2 Visit and interview reports	131
3.3 ICEEF Questionnaire	132

1. Visit reports

1.1 International Fishing Fair 2011 – Ancona, Italy – Visit report

Hybrid Propulsion system by Pronaves

The hybrid system presented at the fair of fishing Ancona consists of a diesel engine and an electric motor with high torque and low speed, keyed directly on the propeller. This electric motor can function as a propulsion engine or electric generator, so at sea, with the internal combustion engine, it will provide electricity on board, allowing to keep off the traditional generator, saving in maintenance, fuel and pollution. The electric motor used as propulsion engine can be used to navigate at low speeds using conventional generators and / or batteries. In this case it creates a propulsion system or a reliable emergency power system, additional to the main engine.

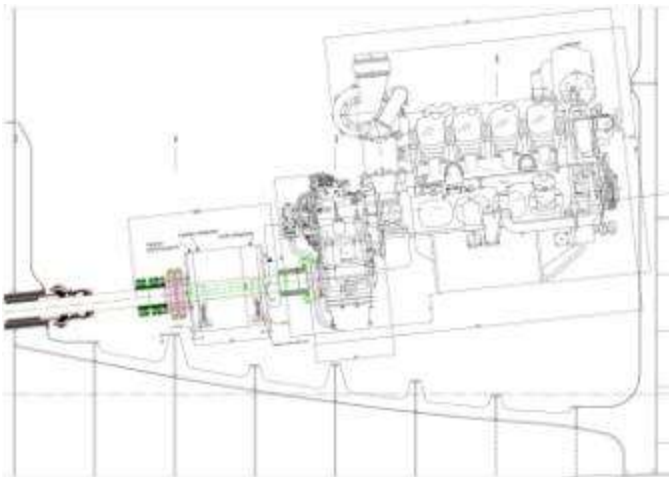

Figure 1. Hybrid system installed onboard a 25 m lft yacht.

The system presented at the fair is capable of 100 kW at 400 rpm, sufficient to produce a continuous torque of 2400 Nm The mechanical connection with the joint axis is accomplished by a chain.

Grilli sas

Energy efficient otter boards

Stainless steel and polyethylene otter board have been designed and built especially to counter the problems encountered on the seabed irregular with mountains of sludge to be back in the presence of such a normal divergent, tends to pierce. To address these issues work has been done on the classic model, AR, without affecting its performance. replacing most of the sheet steel with polyethylene, a plastic material highly resistant but little weight. we obtained a weight reduction of 35% in water reaches 60%.



Figure 3. AR otter board with polyethylene.

B Side otter boards

In order to contain the costs of fisheries management has been developed divergent suitable for both deep water than low ones with the particularity of being able to use this divergent on both sides, ie being able to turn it over to the direction of use. This can be done when the back of the sled is consumed, thus avoiding new shoeing, which in turn reduces maintenance costs.



Fig. 4. B-Side otter boards.

More info at: www.grillisas.com

Ecofishman meeting

EcoFishMan has been invited to the 71st Ancona International FISHING Fair to be held in Italy 27th-29th of May. Several speakers from EcoFishMan will introduce the project to the meeting attendees. The EcoFishMan project is a new EU FP7 RTD project, which will play an important role in the development of a holistic fisheries management system, which takes into account all aspects of sustainability.



The €3.8 million project has been funded under the EU FP7 (EU seventh framework programme) and has a duration of three years. The kickoff meeting was in Reykjavik, Iceland in March 2011. The EcoFishMan consortium consists of the following 14 members: Matis (IS), Eurofish (DK), CETMAR (ES), The Bitland Enterprise (FO), University of Iceland, National Research Council / Institute of Marine Sciences (IT), Nofima Marin (NO), University of Tromsø (NO), Centro de Ciências do Mar (PT), IPIMAR (PT), MAPIX technologies Ltd (UK), Marine Scotland Science (UK), Seafish (UK), and University of Aberdeen.

The aim of **EcoFishMan** is to develop and contribute to implementation of a new integrated fisheries management system in Europe based on increased stakeholder involvement: an ecosystem-based sustainable management system under a precautionary framework that will define maximum acceptable negative impact, target elimination of discards and maintain economic and social viability.

The outcome of this project will be a fisheries management system, developed in collaboration with the important stakeholders in fisheries. The design of the system will take into account ecological, economical and social factors. It will be based on the requirements of the stakeholders themselves and utilise modern technology for surveillance, assessment of stocks and decision supports. This will enhance implementation of the system and improve cooperation and mutual understanding between policy makers and stakeholders.

Technical innovations in fisheries

“Precise registration – Trustworthy documentation” *Henning Skjold-Larsen, SCANMAR, Norway*

For more than 30 years Scanmar as, Norway, has developed and manufactured Catch Control and Catch Monitoring systems for commercial fishing vessels and Fishery Research vessels. More than 250 Fishery Research vessels and thousands of commercial fishery vessels all over the world are equipped with Scanmar equipment.

The system presents all data real time for immediate action, and logged data for later analysis. The system is developed for best possible control of fishing gear performance at any time, independent on fishing condition. Extensive logging functions are provided for later analysis, correction of gear, documentation and planning of further activities.

The Scanmar systems monitor and log data from:

- **Gear performance** (such as trawl gear geometry, trawl door efficiency, trawl functionality, towing speed and direction, and the functionality of gear, sweep lines etc).
- **Environmental data** (such as exact position of influx, water temperature, included temperature profile of water column, underwater currents).
- **Catch** (influx and continuous detailed volume registration).

Scanmar equipment is widely used by Fishing Research vessels to monitor quality of each haul, documentation and analysis. Documented results are; improved overall economy due to increased efficiency (reduced fuel consumption, reduced repair and wear and tear on fishing gear and vessel) and improved quality of the catch.

In addition comes better planning of trips and seasons, and less harm to the environment due to correctly adjustments of fishing gear.

There is little doubt that use of Scanmar equipment contributes to sustainable fisheries by better control, reduced operational costs and better planning.

“e-Audit: energy evaluation onboard Italian fishing vessels” *Emilio Notti, CNR-ISMAR, Italy*

Overfishing and the excess of products in the market with the consequent decrease in their price as well as the rise of fuel price have contributed to diminish profitability in the fishing sector where fuel expenses can go over 50% of the total income. As the price of fuel increases, it becomes more difficult for vessel operators to maintain sustainable profit levels. There are only two possible ways for vessel operators to increase their profits: decrease operating costs, or increase the amount received for their product. Most operators are not able to influence the price

they can receive for their catch. As a result, it is very important that they find ways to decrease operating costs and first of all fuel costs, reducing fuel consumption. Large number of fishing vessels is not energy efficient usually because of outdated technology. The reduction of fuel consumption can be achieved by improving energy efficiency of fishing activities.

To identify feasible ways to reduce energy consumption is necessary a methodical approach and the Energy Audit represents the instrument of this.

In the current experiment some fishing vessels, representing the various fleet sectors of the Italian Fisheries, were selected for an energy audit. Vessels were divided on the basis of type of fisheries and vessel size. An energy audit template was developed to assess the main vessel and equipment features: engine usage, trip scheduling, propeller, etc. Onsite visual inspections were performed during the audit. Using an appropriate acquisition system few parameters were recorded, offering a real-time dynamics. On the basis of the raw data acquired, detailed analysis of energy usage was carried out. Energy performance indicators were developed to display the effective energy efficiency of each vessel, relating to the energy usage and the effective fuel consumption.

“Fuel saving otterboards” *Antonello Sala, CNR-ISMAR, Italy*

A new otterboard has been designed by the Danish Thyboron door manufactures to reduce hydrodynamic drag coefficient and impact on the seabed, as well as to increase door spread. The results have been compared with a traditional Vee door commonly used in the Mediterranean commercial demersal trawl fisheries. The purposes are to discuss the differences between doors, observed during the engineering sea trials. The main results show that it is possible to design new otterboards with up to 15-20% less fuel consumption and up to 40% more door spread.

1.2 IMAM 2011 –Genoa, Italy – Visit report – Fishing Section

The Association was established in 1974 with the acronym of IMAEM (International Maritime Association of East Mediterranean), initially including institutions from six countries (Bulgaria, Egypt, Greece, Italy, Turkey and Yugoslavia). The membership was later progressively enlarged to most of the Mediterranean countries and neighboring areas and, since the 1990 conference, the acronym was changed to IMAM, dropping the reference to the eastern part of the basin.

The International Maritime Association of the Mediterranean (IMAM) is proud of its more than thirty-year-long history committed to the enhancement and dissemination of technical knowledge related to study, design, construction and lifetime operation of ships and other marine structures. The focus of the Association is on the development of marine transports and on the exploitation of sea resources in the Mediterranean area, in line with the principles of a sustainable growth. The IMAM Congresses are privileged forums for the maritime technical community of the Mediterranean. They have been hosted in the following key locations:

Istanbul (1978)	Varna (1993)	Lisbon (2005)
Trieste (1981)	Dubrovnik (1995)	Varna (2007)
Athens (1984)	Istanbul (1997)	Istanbul (2009)
Varna (1987)	Ischia (2000)	Genova (2011)
Athens (1990)	Crete (2002)	

The IMAM conferences are traditional forums for the maritime technical community of the Mediterranean, attended by qualified representatives from the Academia and from Professional and Technical Associations of the various fields involved. The conferences represent therefore a window of opportunity for areas of high potential growth such as the Balkans, Eastern Europe, the Middle and the Near East as well as North Africa.

XIV IMAM Conference

The XIV Conference of the International Maritime Association of the Mediterranean Association of the Mediterranean (IMAM) held in Genoa on Sept. 13th to 16th 2011 under the theme “Sustainable Maritime Transportation and Exploitation of Sea Resources”. The Conference covers the most update aspects of **maritime transports** and of coastal and sea resources exploitation, with focus on the Mediterranean area. Vessels for transportation are analyzed from the viewpoint of ship design in terms of hydrodynamic, structural, and plant optimization, as well as from the perspective of construction, maintenance, operation and logistics. The exploitation of marine and coastal resources is covered in terms of **fishing**, aquaculture and **renewable energy production** as

well as of subsea resources extraction.

The characterization of the marine environment is seen under the twofold perspective of providing reference loads and conditions for the design of means for the resources exploitation, but also of setting limits to the design in order to preserve the natural ambient and minimize the impact of anthropogenic activities related to both transportation and exploitation.

Efficiency, reliability, safety and **sustainability** of sea- and Mediterranean-related human activities are the focus throughout the conference.

Area	Themes
HYDRODYNAMICS	Resistance, Propulsion, Stability
STRUCTURES	Structural design and analysis
MACHINERY AND CONTROL	Propulsion and other plants, Controls, monitoring
DESIGN	Design procedures, Special designs
CONSTRUCTION	Shipyards, Fabrication technologies
SAFETY OF MARINE SYSTEMS	Risk assessment and control: structural reliability, Stability issues, accidental scenarios
MARINE ENVIRONMENT	Characterization of the environment: waves, currents, winds
PROTECTION OF THE ENVIRONMENT	Gas, chemical and noise emissions, Ballast water treatment, Life cycle environmental impact assessment, Alternative fuels and power generation systems
COASTAL DEVELOPMENT	Coastal hydromechanics, ports, Intermodal and logistics issues, Short Sea Shipping
AQUACULTURE AND FISHING	Systems, nets, support boats, Fishing vessels
OFFSHORE DEVELOPMENT	Offshore Hydro-mechanics, Pipeline Technology Renewable Energy Devices
SMALL AND PLEASURE CRAFTS	Work boats, patrol boats Motor and sailing yachts
DEFENCE AND SECURITY	Naval crafts, Security issues for ships

Fishing Section

Fisheries are an underperforming global asset: the margin between the global costs of catching and the value of the catch has narrowed. The economic performance of global marine capture fisheries is determined by the quantity of fish caught, the price of fish, the harvesting costs, and the productivity of the fisheries. Fishing costs vary greatly by type of fishery and locality; in general, the major cost factors, as percentage of total costs, for most fisheries are as follows:

- Labor 30–50%
- Fuel 10–25%
- Fishing gear 5–15%
- Repair and maintenance 5–10%
- Capital cost, such as depreciation and interest 5–25%

This session, as shown by the Chair A. Sala, proves to be an interesting time to compare different realities of European fisheries, from the Mediterranean to the Baltic Sea. Today fishing industry faces different challenges. One of them is raising fuel price. In this paper author analyzed **carbon footprint, fuel consumption, energy use and fishing gear efficiency** in Estonian, Norwegian, Portuguese and Italian fisheries, focusing mostly on energy saving and reduction of carbon emission.

Italian Adriatic Fisheries

Adriatic fisheries are characterized by high diversity, a factor that is reflected in the composition of catches and the structure of the fisheries sector. Adriatic fishing fleet includes all fleet segments, i.e. from small-scale fishery vessels to large trawlers. Commercial catches are represented by demersal fish, crustaceans, shellfish and cephalopods, and pelagic species; the latter are dominated by small pelagic species, mainly sardines and anchovies. The state of heavy exploitation of Adriatic fishery resources is evident and for some stocks is critical. Several different factors, often interacting simultaneously, have affected Adriatic fisheries: Adriatic fisheries production dynamics are based not only on resource availability, but are also strongly driven by market demand and prices.

Estonian fisheries

The Estonian Baltic fleet is now privately owned and concentrated in 8 ports scattered along the coast and islands. The Estonian Baltic Sea fishing fleet at the end of 2004 consisted mostly of trawlers (152 fishing vessels of over 12 m overall length, and 888 vessels of less than 12 m LOA), and the catches are predominately Baltic herring and sprat. At the same time, the Baltic coastal fishery is exploiting the local stocks of valuable brackish water fishes like perch, pike-perch, flounder, eel, sea trout and salmon. Passive fishing gear is mainly used in coastal fisheries. Estonian Baltic catches in 2003 amounted to 59 378 t in total. It is important to note that first-

buyer fish prices have fairly stable from 1996 to 2003, while production costs have increased considerably. For economic reasons, companies have moved to integrating distant-water and Baltic fishing, and fishing and fish processing. Estonia has its own EEZ and its own TAC with a national quota for cod, herring, sprat, and salmon.

Portuguese fisheries

The Portuguese fishing industry is fairly large and diversified. Fishing vessels classified according to the area in which they operate, can be divided into local fishing vessels, coastal fishing vessels and long-distance fishing vessels. The most important fish species landed in Portugal are sardine, mackerel and horse mackerel. Fishing effort is controlled by a licensing system, where acquisition, construction or modification of vessels requires prior authorization. The use of certain fishing methods is also subject to prior authorization and annual licensing. The objective is to allow the modernization of the fishing fleet without increased fishing effort, by authorizing the construction of new vessels only as replacement of others; improving working conditions; and promoting conservation measures by encourage the use of less predatory fishing gear. To achieve this objective, several measures such as fleet renewal and modernization have been adopted to promote recovery and stabilization of the fishing industry and in particular to reduce production costs.

Carbon footprint and energy use of Norwegian fisheries and seafood products

E.S. Hognes, U. Winther and H. Ellingsen - *SINTEF Fisheries and aquaculture, Trondheim, Norway*

F. Ziegler, A. Emanuelsson and V. Sund - *SIK—Swedish Institute for Food and Biotechnology, Gothenburg, Sweden*

About SINTEF fisheries and aquaculture

SINTEF Fisheries and Aquaculture is the leading European technological research institute for the fishing and aquaculture sector with aim of sustainable use of marine resources at a national and international level. It has knowledge and broad competence in the field of the utilization of renewable marine resources. This institute contributes to solutions along the whole value chain - from biological and marine production, aquaculture and fisheries to processing and distribution.

Fisheries technology unit is taking part in the development of the fishing fleet of tomorrow, aiming to achieve a sustainable utilization of the marine resources that is profitable for the fisherman by developing more efficient fishing methods, gear, and ways to better utilize the catch. In the last years, the institute contributed to Energy Saving studies, in particular about Energy optimization of bottom trawls.

SINTEF Fisheries and Aquaculture performed systematic experiments with the various trawl components to examine how they influenced on the towing resistance and global geometry of the gear. These experiments were made in cooperation with many of the manufacturers of trawl gear.

The results were the basis for tuning of mathematical models describing the system. These models were made available for the fishermen in a computer tool, supporting the fishery operations at sea. Bottom trawling is used for many of the most important fisheries in Norway. High energy costs have reduced the profitability to a critical level. Preliminary calculations have shown that optimization of the gear with respect to **energy efficiency** may lead to significant **savings** for the industry. Investigations have shown that most fishing vessels may reduce the towing resistance up to 20% by tuning of the gear. For the Norwegian fleet this will reduce the annual energy costs by approximately 100 mill./NOK, if the oil price remains at the current level.

Abstract

Fuel consumption and emission of cooling agents are important sources for climate impact from the value chain of wild caught Norwegian seafood products. For products that are exported quickly and/or over long distances transport is also an important source. Pelagic products have low carbon footprints due to **energy efficient fishing**, modern refrigeration systems and efficient export methods. The **fuel consumption** per kilo landed products varies a lot in Norwegian fisheries, both within fisheries that use the same gear or that target the same species. This variation shows that there is a high potential to reduce GHG emissions from Norwegian fisheries.

What is LCA and Carbon footprint?

Life Cycle Assessment (LCA) is a method to systematically assess potential environmental impacts associated with the production, distribution and use and end of life treatment of a product (cradle-to-grave). LCA is ISO standardized in their 14 000 series.

What is LCA used for:

- A tool for decision makers to understand the environmental impacts of their products and policies
- Identify opportunities to improve the environmental performance of products at various stages in their life cycle
- A LCA normally include a complementary set of environmental impacts, a Carbon Footprint (CS) is a LCA that only include potential climate impact: Global warming potential.
- LCA can discover environmental tradeoffs with a new technology: Changes in location for environmental impact and/or type of environmental impact

Carbon Footprint:

The sum of GHG emissions from the value chain of the product and processes that underpin this value chain:

- extraction of natural resources/raw materials
- production and distribution of energy and inputs
- construction and maintenance of infrastructure and capital goods

Importance of LCA and Seafood

- Internalization of externalities - What does this mean?
 - Polluter pays
 - A price is put on environmental impacts and this is attributed to the commodities causing it, e.g. CO2 quotas.
- Some facts:
 - More than 30% of environmental impacts from private consumption in the EU arises from food consumption
 - Fishers supply more than 1.5 billion people with 20% of their daily animal protein
 - Steadily increasing population combined with climate change from human caused GHG emissions - We need to produce more with less energy use and less climate impact
- LCA is the preferred method in the EU to evaluate the environmental properties of their policies
- Ecolabeling
 - LCA is the ideal basis for ecolabeling of products
 - Ecolabels for food based on carbon footprints are happening
- Ecodesign
 - Especially important in ship design, many possible trade offs
 - Solving the problem before it appears

Case study

- Goal: Benchmark the carbon footprint of the 22 most important seafood products in terms of export volume and value (Figure 1).
- LCA is a comparative method: Calculation of the climate impact per kilo edible product at wholesaler in different markets. The functional unit was 1 kg edible product.
- Climate impact given as CO₂ equivalents: All GHG emissions are calculated into CO₂ equivalents according to IPCC recommendations based on their chemical/physical properties
- For multi output processes climate impact is allocated between the outputs based on their mass ratio

- Project financed by the Fishery and Aquaculture Research Fund (FHF) on request from the Norwegian's Fishermen's Association (Fiskarlaget) and the Norwegian Seafood Federation (FHL)
- Cooperation between SINTEF Fisheries and aquaculture and the Swedish Institute for Food and Biotechnology (SIK)

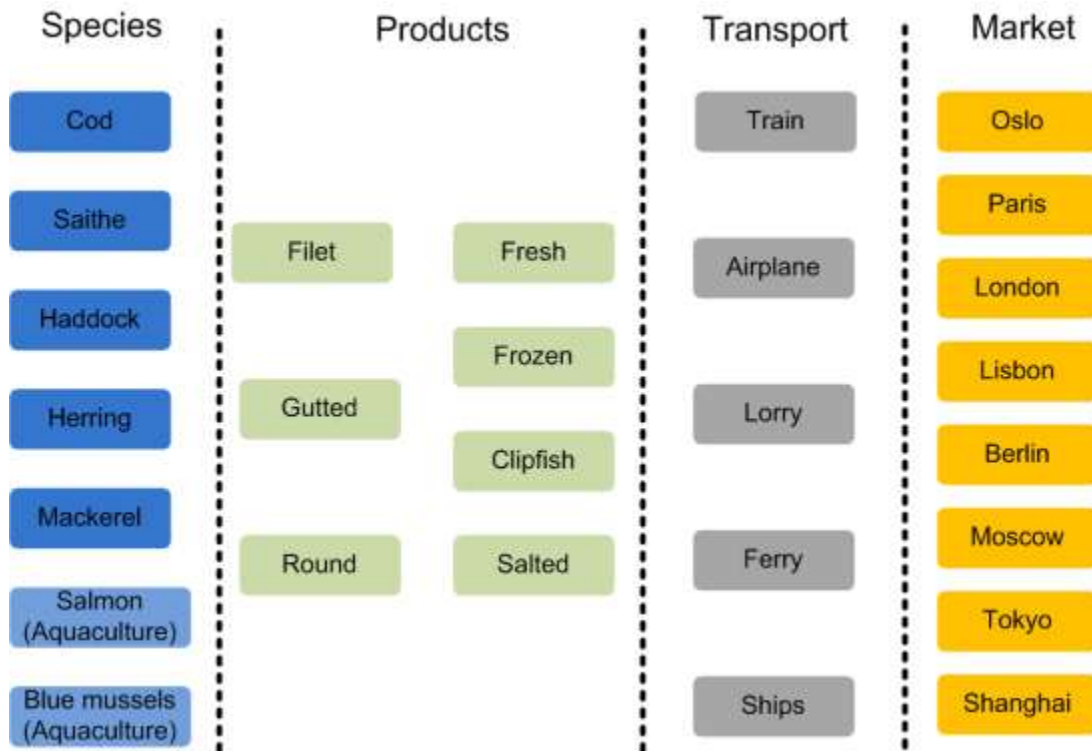

Figure 1. Illustration of the case study

The carbon footprints was calculated with Life Cycle Assessment (LCA) methodology according to ISO 14040: Environmental management—life cycle assessment—principles and framework (ISO 2006). The scope of the assessment was from catch to delivery to wholesaler in different markets. This includes diesel consumption and emissions of cooling agents from the vessels, fuel and energy use in processing and conservation of the fish and finally fuel use, packaging and cooling agent emissions in transports. Figure 2 illustrates the system boundaries for the assessments.

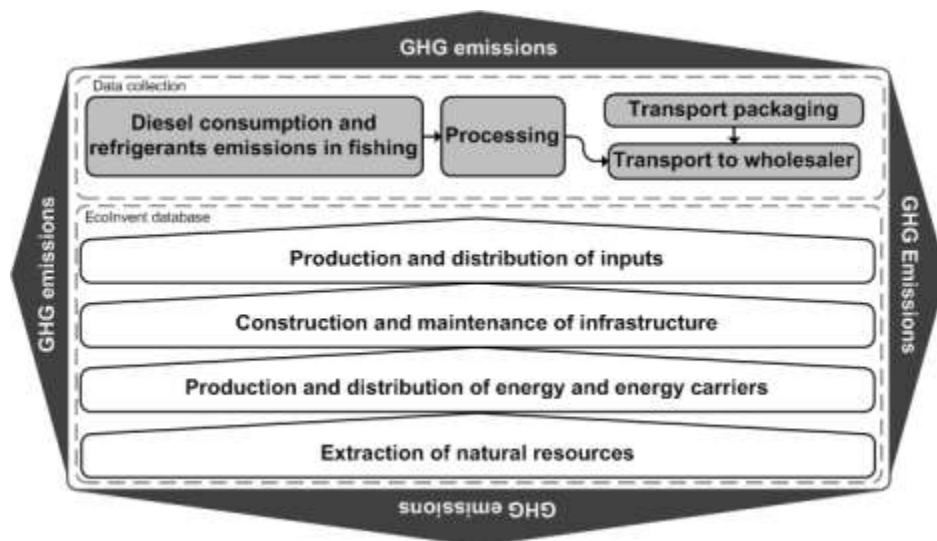

Figure 2. System boundaries for the assessment.

Calculation of gear and species specific fuel factors

The species specific fuel factor (liter diesel combusted to land one kilo of product in round weight) was calculated by combining data on fuel consumption from an annual profitability survey on the Norwegian fishing fleet and sales statistics. Equation 1 shows how the gear specific fuel factors (FS_j) were calculated. The total fuel used by each boat (D_i) was allocated to the different fishing gears it used (FD_{ij}). The allocation was based on the ratio between the boats landing with each gear type (f_{ij}) and the sum of all its landings (F_i). Finally the gear specific fuel factor was calculated by dividing the sum of fuel allocated to each gear by the sum of landings with that gear.

$$FS_j = \frac{\sum_i^n FD_{ij}}{\sum_i^n f_{ij}} = \frac{\sum_i^n \frac{f_{ij} D_i}{F_i}}{\sum_i^n f_{ij}} \quad (\text{Eq. 1})$$

Explanation of terms in Equation 1:

- FS_j : Fuel factor for gear j [l/kg]
- FD_{ij} : Fuel allocated to gear j on boat i [l]
- f_{ij} : Landings with gear j on boat i [kg]
- D_i : Total (annual) fuel consumption by boat i [l]
- F_i : Sum of all landings by boat i [kg]
- n : number of boats in profitability survey after data corrections.

Data from more than 450 vessels was used and the calculation of fuel consumption in different fisheries resulted in the gear specific fuel factors presented in Table 1 and the species specific fuel factors presented in Table 2.

Table 1. Gear specific fuel factors from profitability survey in Gear specific fuel factors from the 2007 profitability survey.

Fishing gear	Average — liter fuel / kg landed in round weight	Standard Deviation
Long-line (autoliners)	0,31	0,12
Bottom trawl	0,43	0,24
Double trawl	0,94	0,31
Pelagic trawl	0,10	0,12
Pelagic pair trawl	0,09	0,02
Hand line/ jig	0,15	0,19
Gillnet	0,15	0,18
Purse seine	0,089	0,03
Danish seine	0,12	0,20

Table 2. Species specific fuel factors.

	Fuel factors — liter fuel / kg landed round weight	Standard deviation
Cod	0.24	0.10
Haddock	0.29	0.11
Saithe	0.29	0.13
Herring	0.09	0.03
Mackerel	0.09	0.03

Results And Discussion

- Fuel consumption and emission of cooling agents from refrigeration systems are in general the most important climate aspects for Norwegian wild caught demersal- and pelagic products.
- Pelagic products have the lowest carbon footprints due to energy efficient fishing, refrigeration systems with low emissions and efficient export methods (Table 1).
- Among the demersal species cod is caught with the least climate impact. The main reason for that is that a big part of the annual catch of cod is done by coastal fisheries that use passive fishing gears such as gillnet close to shore, while more of the haddock and saithe is caught with trawlers and autoliners further away from land.

Figure 3 presents the total carbon footprint for Norwegian wild caught seafood products to different export markets — and on different transport means.

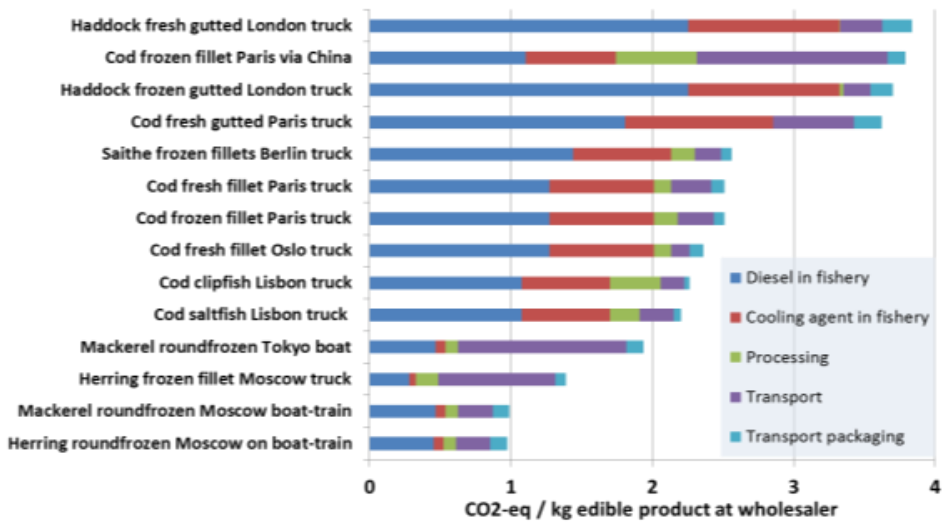

Figure 3. Carbon footprint of Norwegian wild caught seafood.

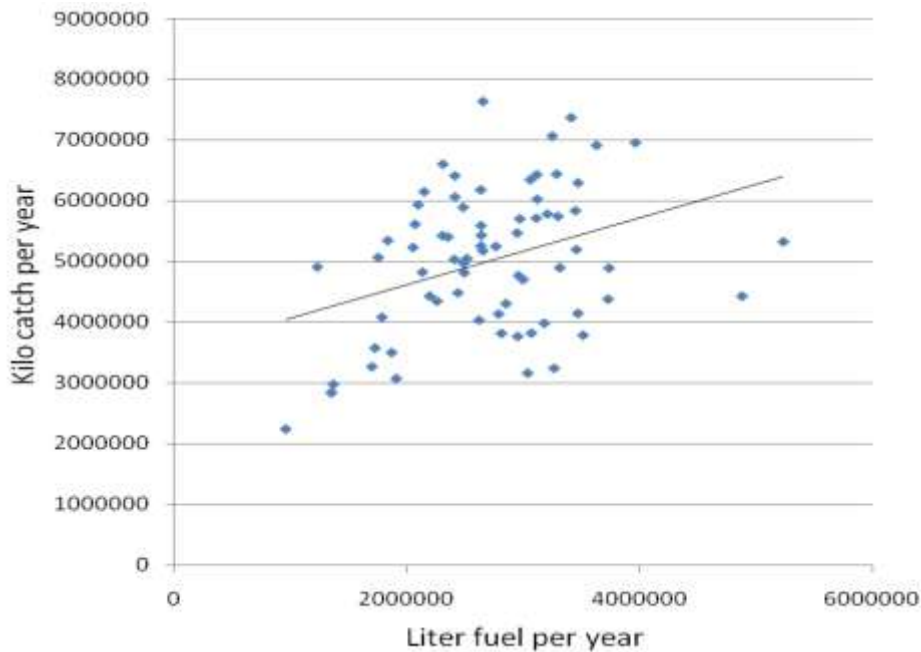

Figure 4. Annual catch and fuel consumption of factory trawlers. Data from profitability surveys, 2001 to 2007.

Figure 4 shows a plot of the annual fuel use and annual catch by Norwegian factory trawlers from 2001 to 2007, the variation illustrated here is not influenced by calculations since it is only based

on the catch and fuel consumption reported by the vessels. These are vessels that use the same type of gear, that target the same species in the same areas and that operate within identical regulatory and environmental frames.

Energy efficiency in fisheries

The energy use in fisheries is a complex function of biological, technological, political, economical and human factors, examples:

- Total available quotas and quota allocation policies
- Structural policies
- Technical regulations and spatial and temporal limitations of fisheries
- The "skipper effect"
- Natural variations in stock size and behaviour
- Sales systems and oil prices

When searching for the pathway towards fisheries with less energy use and climate impact all of these factors need to be taken into account.

This list emphasizes how important it is to approach energy efficiency improvements in fisheries with a system perspective; technologies need to be improved, the fishermen need to use the available technology better and the framework this technology is developed and invested in needs to be focused on achieving climate and environmental improvements.

The fuel factors calculated here were compared with data from some of Norway's biggest fishing vessel owners and scientific reports and articles e.g.: (Tyedmers 2001; Eyjólfsdóttir, Yngvadóttir et al. 2003; Thrane 2004; Tyedmers, Watson et al. 2004). Some of these results are represented in

The calculated fuel factors for the demersal fisheries are lower than the values reported in previous studies. Gear specific fuel factors from literature and vessel owners.

Some reasons are:

- Higher fuel prices leading to a more fuel-saving behavior,
- improved stock status with higher catches per effort
- higher quotas
- regulatory schemes to decrease unprofitable over capacity in the Norwegian fishing fleet.

From 2002 to 2007 the number of Norwegian fishing vessels decreased from 2206 to 1709, while the total landings of demersal species increased by 6% and landings of pelagic species decreased by 20%, the decrease in pelagic fisheries was mainly due to lower landings of blue whiting, which is an energy intensive fishery, but the landings of Norwegian spring spawning herring increased.

Fishing gear	Liter fuel/kg round weight	
	Average value	Data range (min–max)
Bottom trawlers	0.63	0.33–1.0
Purse seiners	0.077	0.036–0.11
Long liners	0.31	0.18–0.49

To conclude; fewer boats catch with higher quotas has increased the energy efficiency of Norwegian fisheries.

Conclusion

- Food consumption and production is an important source of environmental impacts
 - We need to produce more with less
 - Internalization of externalities: Environmental impacts will be put into the price of your product.
- For wild caught seafood products important climate aspects are
 - Energy use and refrigerants emissions from the fishing vessels
 - Export method
- Energy use in fisheries is a complex equation with human, biological, technological and political factors
- Understanding LCA and carbon footprint is becoming a request for technology and policy developers
- LCA is about understanding your risks and discovering your advantages

The carbon footprint of wild caught Norwegian seafood consists of many important climate aspects. To reduce the climate impact from seafood products there is need of more energy efficient fisheries with renewed refrigeration technology. The high level of variation in the fuel consumption of Norwegian fisheries show that there is a potential for massive reductions of GHG emissions if the vessels that today have the highest fuel consumption can lower their expenses to the level of those that use the least. This can be done by improving how the fisheries are performed (fishermen’s behavior and their technology), but just as important by making sure that the regulatory frames they work within promotes energy efficiency improvements. By insuring that the carbon footprint of seafood products becomes a competitive parameter in the seafood markets it can promote these improvements; the link between reducing environmental impacts and economic profitability will become strong and direct.

Fuel efficiency in trawlers under different fishing tactics using a consumption model and VMS data: a case-study for the Portuguese fleet

A. Campos, T. Pilar-Fonseca, J. Parente and P. Fonseca - INRB, IP/IPIMAR, Lisboa, Portugal

M. Afonso-Dias - Centro de Investigação Marinha e Ambiental, Universidade do Algarve, Faro, Portugal

About IPIMAR

IPIMAR is the only governmental fisheries and aquaculture research laboratory in Portugal. IPIMAR carries out strategic research and **technological development** on management and conservation of marine living resources, aquatic environments, pollution, toxicology and shellfish and fish aquaculture, ensuring scientific and technical support for policies defined by the Portuguese Ministry of Agriculture and Fisheries. It has a record spanning more than forty years in multi-disciplinary studies related to marine science and consequently has a number of staff with expertise in fisheries, aquaculture and marine research. IPIMAR has been, in recent years, a partner and co-ordinator in many national and international research projects in all fields of its activity.

Recently IPIMAR is involved in EC research project about Energy Saving in Portuguese fishing fleet. Special attention was given to the results obtained by the introduction of the new trawl led to an increase of winged spread times vertical opening at working speeds higher than 4.2 knots, and though, to a better trawl performance at higher speeds. The new exploitation pattern resulted in a decrease of 13% in the trawling fuel rate. Further commercial trials with this trawl showed excellent results and at the moment it is known that a considerable number of trawlers of that size and power have adopted, or intend to adopt, the new trawl.

Abstract

Trawling is the most fuel-intensive fishing activity, with trawlers constituting the fleet segment most affected by the high volatility of the **fuel prices**. This is likely to be a main driver for adopting **fuel consumption** reduction strategies, which may be related to alternative fishing practices. In this study, individual vessel trajectories obtained from Vessel Monitoring System (VMS) data processed by GIS software (GeoCrust 2.0) are used to characterize a number of operational and economical parameters, for different landing profiles, corresponding to fishing trip types with specific landings composition. This information is combined with fuel consumption estimates derived from a mathematical model for the distinct phases of a round fishing trip, providing an insight into the **profitability of fishing operations**.

Portuguese fleet

At present, a total of around 100 vessels are active in the Portuguese coastal bottom trawling, corresponding to 15000 GT (gross tonnage) and 40000 of engine power (kW). This fleet accounted for approximately 12 and 18% of the total national landings in continental waters, in weight and

value, respectively (DGPA, 2010). Fishing pressure is high and the fishing activity taking place all year round and exploiting a large number of fish, cephalopods and crustaceans species.

What is VMS?

A fishing vessel monitoring system (VMS) is a program of fisheries surveillance, in which equipment that is installed on fishing vessels provides information about the vessels' position and activity. This is different from traditional monitoring methods, such as using surface and aerial patrols, on-board observers, logbooks or dockside interviews. Vessel Monitoring Systems (VMS) have greatly increased the potential efficiency of Monitoring Control and Surveillance of fishing vessels (MCS). In the last few years several countries have introduced VMS which enable the activities of fishing vessels to be monitored and indeed for such vessels to actively report on catches to the fisheries management authority. Coastal States, which apply VMS to national and foreign fishing vessels licensed to fish in their EEZs, can monitor the activities of such vessels very effectively and economically, thereby increasing the effectiveness of their MCS.

VMS use in Portuguese fleet

Information on vessel activity (including georeferenced data) on a trip level is of utmost importance for understanding Portuguese fleet strategies in fishing effort allocation and contributing to the design of efficient energy management solutions. This is now possible due to the existence of high spatial resolution data provided by the satellite-based Vessel Monitoring Systems (VMS), which collect observations on single vessels operation and may provide detailed effort on a highly disaggregated spatial scale. The data can then be related to landings revenues and running costs (i.e., the costs depending on vessel specific effort allocation in time and space, such as fuel costs), providing information on vessel profitability. Taking this information into account, **fuel efficiency** may be tackled, for instance by adopting the best running point, that is, the vessel's operating speed, both in trawling and in free navigation, that maximizes net income.

Methods

- Sample Vessel
 - coastal fish trawler 24 m LOA
 - 600 HP
 - target species: horse mackerel, cephalopods and demersal fish species
 - operate under 3 distinct LP
 - good coverage in terms of VMS data
- Landing profile (LP)
 - horse mackerel (LP5)
 - horse mackerel with demersal species (LP3)
 - demersal species, mainly octopuses and pouting (LP1)
- GeoCrust 2.0 (Afonso-Dias et al., 2004; 2006)
 - Geo-referenced information (spatial dynamics of the trawl fleet)
 - High-quality fishing trips

The GIS allows for the identification of individual FT (fishing trip) and the corresponding main operational phases:

- navigation from port to the fishing ground;
 - trawling (fishing);
 - navigation between fishing grounds;
 - and navigation to the landing port.
- Consumption model (Parente, 2009) estimates for each operational phase of the FT
 - Total fuel consumption
 - hourly consumption
 - engine performance
 - engine power output
 - emissions expelled into the atmosphere

Aim of study

The data above were used to calculate a number of statistics and to derive different indices characterizing the two phases of the FT under each LP, in terms of their **operational behaviour**, **energy efficiency** and **economic results**.

Results

- Geographical location of fishing activity was not found to differ much between LP (Figure 4)
- Differences in trip duration between LP are evident, with longer trips when benthic species are targeted (LP1)
- Fuel consumption was highly correlated with trip duration
- Fuel consumption by LP varied between 927 and 1852 litres (for LP3 and LP1, respectively)

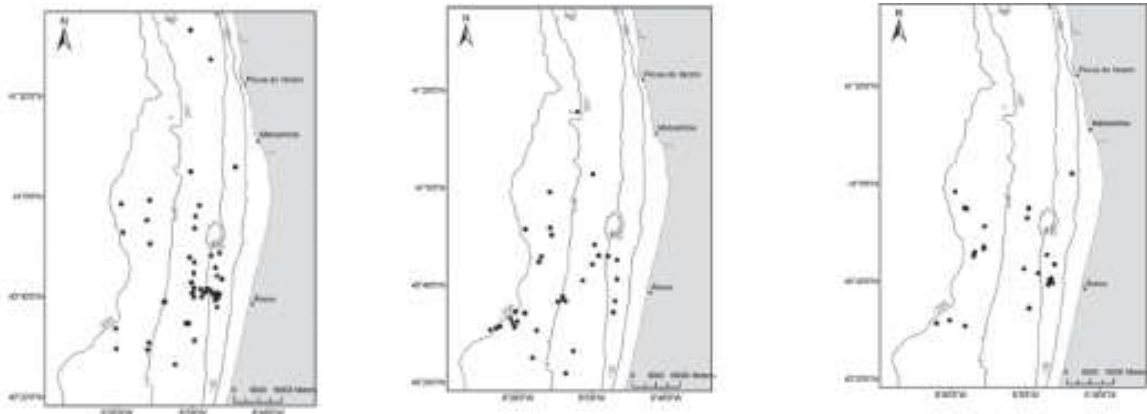

Figure 4. Geographical distribution of vessel activity by LP (LP1, LP3 and LP5) during 2003. Each point corresponds to the first VMS trawling position for each trip. VMS information processed by GeoCrust 2.0. Mapped using ArcGis software.

- Hourly consumption during trawling was found to be a constant value (85 l/hour trawled).
- During non-trawling phases consumption was, significantly lower (28.5 and 32.3 l/hr; Table 3 and Figure 5).
- Notwithstanding the unobserved differences among LP in hourly fuel consumption during trawling, fuel efficiency (landings per fuel consumed) varied, both in quantities and in value (Figure 7).
- Fuel costs represent 11%— $(1/8.8)*100\%$ —of the sales value for LP5 compared to 21%— $(1/4.8)*100\%$ —in LP1 (Figure 7).
- Higher trip profitability was generally observed in the first semester, which is related to trips targeting horse mackerel (Figure 8).

Table 3. Average trip estimates for effort, LPUE, fuel consumption and economic indicators by LP for the vessel in study. High-quality data processed by GeoCrust 2.0. LP named according to Pilar-Fonseca et al. (2009). Standard deviations in parenthesis.

Estimates	LP		
	LP1	LP3	LP5
Percentage of FT in the LP ¹	41.4	27.3	20.3
Trip duration (h) ²	28.1 (14.9)	15.7 (9.3)	22.4 (18.9)
Number of hauls	8.1 (4.5)	4.9 (2.6)	6.5 (5.1)
Trawling time (h) ²	18.9 (10.9)	8.1 (5.5)	12.5 (12.4)
Trawling speed (kt) ²	3.8 (0.2)	4.1 (0.2)	4.0 (0.2)
Non-trawling speed (kt) ²	5.9 (1.1)	7.0 (1.0)	6.6 (1.3)
Ratio between trawling time and trip duration	0.65 (0.10)	0.50 (0.12)	0.53 (0.14)
Ratio between fuel consumption in trawling and total fuel consumption	0.8 (0.1)	0.7 (0.1)	0.7 (0.1)
Hourly fuel consumption during trawling (l/hour trawling)	84.5 (0.2)	84.7 (0.2)	84.7 (0.2)
Hourly fuel consumption (l/hour at sea)	65.3 (4.7)	58.9 (5.2)	60.0 (6.7)
Landed weight (kg)	885.8 (459.2)	866.2 (499.0)	1660.0 (1183.5)
Landed value (€)	2375.5 (459.2)	1849.4 (499.0)	3170.3 (1183.3)
Price (€/kg)	2.8 (0.8)	2.3 (0.7)	2.0 (0.9)
Landed weight per fuel consumed (Kg/l)	0.6 (0.3)	1.1 (0.7)	1.4 (0.7)
Landed value per fuel consumed (€/l)	1.5 (0.9)	2.3 (0.7)	2.7 (1.0)
Horse mackerel LPUE (kg/h)	6.2 (5.9)	61.8 (50.4)	130.3 (79.4)
Octopuses LPUE (kg/h)	10.9 (6.3)	5.6 (5.5)	4.7 (5.1)
Landed value per hour trawling (€/h)	148.7 (90.2)	293.0 (204.0)	313.3 (182.3)
Ratio between total revenues and fuel costs	4.8 (2.6)	7.7 (4.7)	8.8 (4.8)

¹Percentage; ²Input parameter for the fuel consumption model.

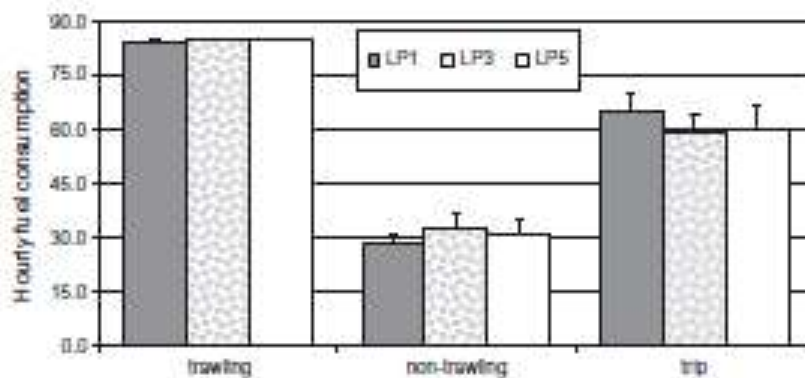

Figure 5. Fuel consumption in L/hr by operational phase (trawling and non-trawling), trip and LP

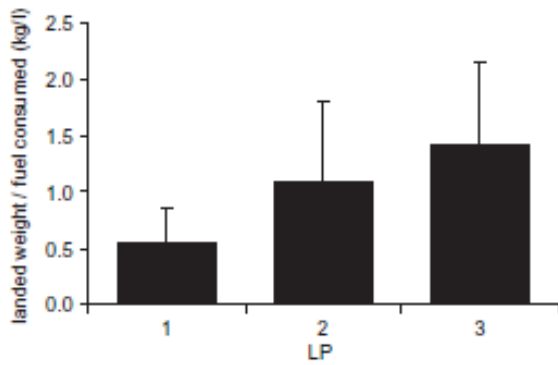

Figure 6. Fuel efficiency ratio (landings in weight per fuel consumed, kg/l) by LP, assuming an average fuel price of 0.3 €/l in 2003, for the sample trawler.

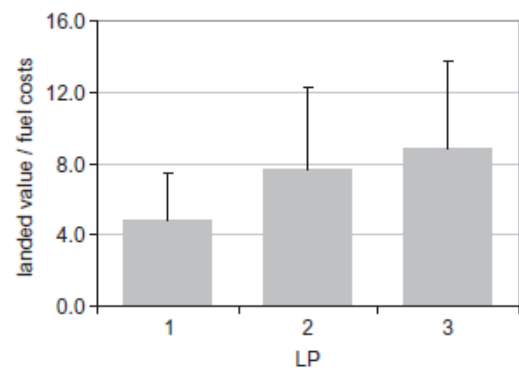

Figure 7. Ratio between landings in value and fuel cost by LP in 2003, for the sample trawler.

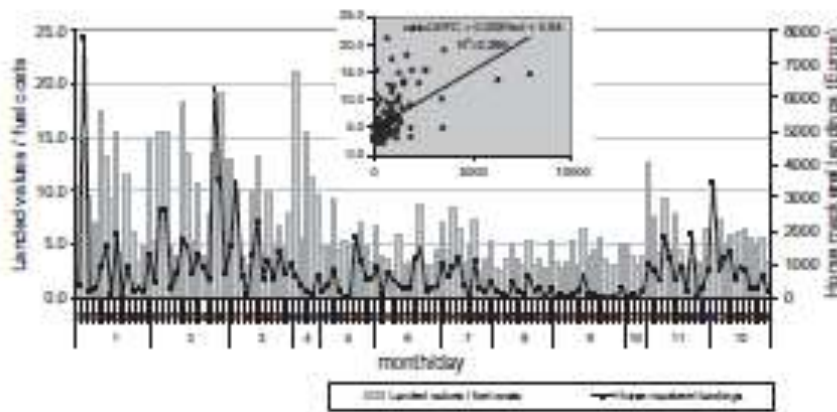

Figure 8. Ratio between Landings in Value and Fuel Cost (ratio LV/FC, y-axis) by date of fishing trip (month and day, x-axis) in 2003. Secondary y-axis contains horse mackerel landings in value (€). Relationship between ratio LV/FC and horse mackerel landings ($r^2 = 0.299$).

Final Considerations

This case study represents a first attempt about:

- integration of different sources of information obtained at the trip level
- better characterization of trawling activity
- estimation of **energy efficiency** and **economic indicators** for the different fishing tactics.

Differences in **fuel consumption** and overall **economical efficiency** between octopuses and horse mackerel LP may indicate that there is room for changes in operational procedures for demersal species fishing trips (LP1), in order to optimize their return.

Towards sustainable Baltic herring fishery: trawls vs. pound nets

T. Raid, H. Shpilev and L. Järv - *Estonian Marine Institute, University of Tartu, Tallinn, Estonia*

A. Järvik - *Estonian Maritime Academy, Tallinn, Estonia; Estonian Marine Institute, University of Tartu, Tallinn, Estonia*

About Estonian marine institute

The main goals of the fundamental scientific activities of the Estonian Marine Institute are:

- exchange of matter and energy between the ecological subsystems of the Baltic Sea;
- structure, dynamics and functioning of the Baltic ecological subsystems and their internal exchange of matter and energy;
- changes in the ecosystems caused by natural and human impacts
- development of the ecosystem and prognostic models and their verification.

The main efforts in applied science are:

- stock assessment of fish and macroalgae of the Baltic Sea, composition of forecasts of possible catches and management advice;
- marine monitoring, incl. Participation in national and in the HELCOM Baltic Sea Marine Monitoring Program
- expert evaluations and contracts (e.g., environmental impact assessments).

Abstract

The Baltic herring is traditionally one of the main targets of Estonian fishery. The annual catches of Baltic herring have ranged 22-58,000 t or 15–25% of the total herring catch in the Main Basin and the Gulf of Riga since 1991. The international management of the Baltic herring stocks includes Total Allowable Catch and some technical measures (gear restrictions, closed areas and periods) as management tools. However, the selectivity studies of herring trawl fishery have shown the no efficiency of mesh size regulation. Additionally, the implementation of closed seasons/areas may result in undesired accumulation of excess effort. The paper is focusing on another management tool—an optimizing the balance between herring trawl and pound net fisheries. The pound net catches include substantially higher share of older age groups with higher mean weights and no by-catch of juvenile fish, often taken by trawl fishery. Due to the different catch structure, the average number of fish, taken in order to achieve the similar catch in tons (population loss) is considerable smaller in pound net fishery than in trawl fishery, indicating that higher share of pound-net fishery might allow to decrease the fishing mortality.

Estonian herring fishery

The Baltic herring (*Clupea harengus* L.) is traditionally one of the main targets of Estonian fishery. The Estonian fishery exploits two Baltic herring stocks:

- *Central Baltic Herring* (CBH) located in the ICES sub-divisions 25–28, 29 and 32
- Gulf of Riga herring (Sub-division 28.1).

Substantial changes in the structure of fishery started in 1950s with fast development of pelagic trawl fishery in 1960–1962. The alteration in the structure of herring fishery towards the use of trawls in Estonia has had effect on:

- seasonality of fishery
- catch composition
- exploitation rate
- **herring fishery costs**
- social situation.

Based on the most recent estimates of fishing mortality, ICES classifies the both herring stocks as being harvested unsustainably (the Gulf of Riga herring) or being at risk to be harvested unsustainably (Central Baltic herring, ICES 2010a).

The present study is focusing on another possible management tool—an optimising the balance between herring trawl and pound net fisheries in order to control the fishing mortality and **fisheries profits**.

Discussion

Fishing mortality

The studies of the effect of vessel and gear size on herring the Gulf of Riga herring stock showed that the large vessels using big pelagic trawls cause a substantial additional fishing mortality of younger herring compared to the smaller vessels.

Pelagic Trawl – Mesh size regulation

The estimates the effect of mesh size regulation on unaccounted mortality of the Baltic herring in pelagic trawl fishery, have shown that the share of survived escapees of Baltic herring is generally very low (8.8%) independently of mesh size in the length groups below 12 cm (TL). That leads to the conclusion that the implementation of mesh size restrictions as main regulatory measure in herring trawl fishery in the Baltic is rather problematic and the additional regulatory measures are needed.

Pound net

The pound net (Figure 9) catches include substantially higher share of older age groups and no by-catch of juvenile fish, often taken by trawl fishery. Additionally, the mean weight at age of pound-net catches is higher compared to the trawl catches. So, in the Gulf of Riga herring the average mean weight at ages 2–7 in trawl catches made up just 89% of the respective values in pound-nets.



Figure 9. Pound net fishery.

Conclusions

The extensive development of trawl fishery would lead to unnecessarily big losses in abundance while the quality of catch (condition of fish, mean weight at age) is usually lower than that of in pound-net/trap-net fishery.

In addition, costs related to pound net fishery are significantly lower than those of the pelagic trawl. Several factors continue to undermine pelagic trawl fishery productivity. These include rising oil prices; rising costs of fishing gear and vessels, often compounded by unfavorable exchange rates (for countries that import factors of production); an increasing regulatory burden; and depletion of inshore stocks, causing fishers to travel farther to fishing grounds.

By contrast, non-motorized fisheries, fisheries that use passive gears (such as traps or pound net) and thus relatively less fuel, may obtain an **improvement in profitability** in this period.

1.3 IMAM 2011 –Genoa, Italy – Visit report – Engineering Section

A mathematical model of the propeller pitch change mechanism for the marine propulsion control design

M. Altosole & M. Martelli - Department of Naval Architecture and Electrical Engineering, Genoa, Italy - S. Vignolo - Department of Production Engineering, Thermal Energetic and Mathematical Models, Genoa, Italy

Abstract

The paper is mainly focused on the mathematical model of the control pitch mechanism for a marine controllable pitch propeller (CPP), able to perform the propeller blade position change and to give a proper information about the oil pressures, produced inside the CPP hub. In fact, too high pressures can be responsible for the mechanism failure, then they should be always under examination by the ship automation. With regard to the traditional representation of the few spindle torque data reported in literature, in the proposed mathematical model the transportation inertial forces and the Coriolis inertial forces acting on the propeller blade are evaluated taking into account the yaw motion of the ship, the propeller speed (including shaft accelerations and decelerations) and the blade turning during the pitch change. On the basis of the introduced procedure, it is developed the CPP model which is part of an overall propulsion simulator, representing the dynamic behaviour of a twin-screw fast vessel. The aim of the work is to represent the ship propulsion dynamics by time domain simulation, on the ground of which the automation designers can develop and test several propulsion control options. A brief description of the simulation approach adopted for the vessel crash stop is illustrated at the end of this paper. In particular, the propulsion control action is studied taking into account machinery performance and constraints, including also the control pitch mechanism feedback in terms of allowable forces and pressures.

Latest experiences with contracted and loaded tip (clt) propellers

Juan Gonzalez Adalid - *SISTEMAR s.a, Madrid, Spain* - Giulio Gennaro - *SINM s.r.l., Genoa, Italy*

Abstract

Since 1976 tip loaded concept has been evolved continuously. Presently SISTEMAR's CLT propellers are installed on about 280 vessels worldwide. Despite this fact the use of CLT propellers has been curtailed due to the lack of specific knowledge of this type of propeller and due to the fact that CLT propellers need a different model-to-full-scale extrapolation methodology in respect with conventional propellers.

The conclusions that can be drawn from more than 30 years of model and full scale experiences are the following:

- CLT propellers are a fully developed technology;
- CLT propellers grant several significant advantages over conventional propellers, the most important being:
 - 5 to 8% higher efficiency over the entire operational range (i.e., 5 to 8% fuel saving and 5 to 8% reduced emissions);
 - lower induced noise and vibrations;
 - Improved ship maneuverability characteristics;
- CLT propellers are extremely indicated for new buildings and very attractive for ships in service.

Main characteristics:

CLT propellers are characterized by the following:

- The blade tip generates a substantial thrust.
- The pitch increases from the root to the tip of the blades.
- The chord at the tip is finite.
- End plates are fitted at the blade tips, toward pressure side; they are adapted to the fluid vein contraction to reduce as much as possible their viscous resistance.

The fundamental goal of the CLT propeller is to improve the propeller open water efficiency by reducing the hydrodynamic pitch angle through the reduction of the magnitudes of induced velocities at the propeller disk.

As the blade area of the CLT propeller is more efficiently used for supplying thrust, the optimum diameter is lower than for an equivalent conventional propeller.

CLT propellers offer higher efficiency which may be used to achieve fuel savings at constant ship speed or alternatively ship speed increase at constant fuel consumption. Trawlers and tugs achieve an increase of the pulling force.

The downstream overpressure produced by a CLT propeller is higher than for an equivalent conventional propeller. This increases the pressure on the rudder and so increases the ship's response to rudder action, leading to a substantial reduction of the turning circle for any given rudder angle; a reduction of both time and distance required to stop the ship in a crash stop maneuver and an increase of the ability to maintain a rectilinear course.



Figure 4. CLT non conventional propellers

The advantages of CLT propellers over conventional propellers resulting from full scale installations and from several comparative full scale trials and long term observation are the following:

- Higher efficiency (between 5 and 8%)
 - Fuel saving
 - Reduced emissions
 - Saving on MM/EE maintenance
 - Higher top speed
- Greater range Inhibition of cavitation and of the tip vortex
 - Less noise
 - Less vibrations
 - Lower pressure pulses
 - Lower area ratio
- Greater thrust
 - Smaller propeller optimum diameter
 - Better maneuverability.

Endplate effect propellers: a numerical overview

Stefano Gaggero & Stefano Brizzolara - Department of Naval Architecture, Marine Engineering and Electrical Engineering (DINAEL), - Genoa University, Genoa, Italy

Abstract

Energy saving is a primary objective, historically the first and, probably still now, the most important one, in the design of marine propellers. Modern design approaches, like fully numerical lifting line/lifting surface codes and optimization applied to potential panel methods satisfy this objective and allow to design conventional propellers with maximum efficiency for a given operating point. On the other hand nonconventional propellers, like CLT and Kappel like geometries, represent a further opportunity to increase efficiency and reduce the risk of cavitation. In the present work a numerical analysis of unconventional propellers will be carried out. Two different numerical approaches, a potential panel method and a RANS solver will be employed. The analysis will highlights the peculiarities of these kind of propellers, the possibility to increase efficiency and reduce cavitation risk, in order to exploit the design approaches already well proven for conventional propellers also in the case of these unconventional geometries.

One solution for all emission challenges? an overview about the reduction of exhaust emissions from shipping

Dirk Thum - Head of Emission & Gas, Marine Medium Speed, MAN Diesel & Turbo SE, Denmark
Robert Brendel - Marine Medium Speed, MAN Diesel & Turbo SE, Denmark

Abstract

In the light of the new IMO emission regulations, several options can be chosen to reach the requested limits. These options contain low-sulphur fuels or after treatment systems for desulphurization and SCR or exhaust gas recirculation to cope with the NOx limits. The right technology of choice largely depends on the vessels properties and its operation profile. 4-stroke vessels operating only a limited time in an ECA, the right technology will be chosen based on the lowest investment costs. Then, the use of an SCR for NOx-reduction while burning MGO is recommended. Increasing the time spent in an ECA will move the focus more to operating costs. Therefore the combination of cheap fuels like HFO with exhaust gas after treatment becomes reasonable. Additionally, the dual fuel option will be more of interest and due to its low fuel costs, it can be recommended for a lot of different applications in the foreseeable future.

Evaluation of ship efficiency indexes

M. Figari - Naval Architecture, Marine Engineering, Electric Engineering Department, University of Genoa, Italy - M. D'Amico D'Amico Shipping Company, Rome, Italy - P. Gaggero Registro Italiano Navale, Genoa, Italy

Abstract

IMO is introducing two different emission indexes for a vessel: the Energy Efficiency Design Index (EEDI) and the Energy Efficiency Operational Indicator (EEOI). The former will be used to assess the design of the vessel, the latter would be used to evaluate the vessel in operation. Both indexes represent the ratio between emissions, in mass of CO₂, and the transported cargo quantity per sailed distance. At moment an important debate is focusing on the definition of the 'baseline' values for different ship categories. The collaboration between D'Amico Shipping Company, Registro Italiano Navale and Department of Naval Architecture, Marine Engineering, Electric Engineering of Genoa University provided the framework for a study aimed to evaluate the carbon footprint of the vessels of the D'Amico fleet, the analysis of various aspects of factors effecting the carbon dioxide emissions caused by ships and improvements of fleet energy management techniques. The results of the study can be divided into two main aspects: it is a picture of the actual carbon dioxide emission status of a cargo fleet and it gives the technical instruments and measure tools to start an emission control policy with reference to a ship energy efficiency management plan.

A new approach in engine-propeller matching

A. Coraddu, S. Gaggero, D. Villa & M. Figari - Department of Naval Architecture, Marine Engineering and Electrical Engineering (DINAEL), Genoa University, Genoa, Italy

Abstract

Traditional engine-propeller matching techniques are mainly based on non-dimensional parameters analysis: thrust/advance coefficient or torque/advance coefficient ratio are the most used variables to assess the ship propulsion point or to match, at each selected ship speed, the selected propeller with the ship engine. The advantages of this robust and well established procedure (standard propeller open water measures only at some pitch ratios around the design configuration, availability of large databases and extrapolation laws) however, turn into the drawbacks for the inclusion of different constraints and objectives, further than the minimum fuel consumption, in the matching algorithm. On the other hand modern numerical tools and available hardware resources let to partially substitute, in the design stage, experimental campaigns and to collect large amount of information on propeller performances, including cavitation. In this sense numerical computations make out of date approaches just developed to overcome the deficiency of experimental measures. On the basis of these numerical data new algorithms for the engine-propeller matching can be developed capable of investigate different objectives and the influence of different constraints on the traditional optimum points.

Numerical and experimental optimization of a cp propeller at different pitch settings

D. Bertetta, S. Brizzolara, S. Gaggero & M. Viviani - Department of Naval Architecture, Marine Engineering and Electrical Engineering (DINAEL), - Genoa University, Genoa, Italy - L. Savio - Rolls-Royce University Technology Center 'Performance in a Seaway' Department of Marine Technology, Norwegian University of Science and Technology, (formerly DINAEL) Norway

Abstract

Propeller design is an activity which nowadays presents ever increasing challenges to the designer, involving not only the usual mechanical characteristics and cavitation erosion avoidance, but also other side effects, such as radiated noise and/or pressure pulses. Moreover, in some cases propeller characteristics have to be optimized in correspondence to very different functioning points, including considerably off-design conditions, which are hardly captured by conventional design methods. In present paper, a recently presented method, based on the coupling between a multiobjective optimization algorithm and a panel code, is applied to the design of a CP propeller at different pitch settings, with the aim of reducing cavitating phenomena and, consequently, resultant radiated noise. Numerical results are validated by means of an experimental campaign at cavitation tunnel, showing the capability of the method to assess propeller functioning characteristics, thus representing a very useful tool for the designer in correspondence of challenging problems.

Combustion chamber of the diesel engine—theory and numerical simulation

L.C. Stan & N. Buzbuchi - Constanta Maritime University, Constanta, Romania

Abstract

The simulation of the processes inside the marine engines was a permanent subject of study for the specialists. The complexity of all the associated phenomena and their strong correlation is making out of this a very difficult task. This paper tried to simulate the combustion inside the marine diesel engine using the newest computer methods and technologies with the result of a diverse and rich palette of solutions, extremely useful for the study and prediction of complex phenomena of the fuel combustion. The paperwork is tridimensional modeling of the geometry of the combustion chamber and the CFD (Computational Fluid Dynamics) net/grid of the finite elements involved and tridimensional simulation of the thermo-chemical behavior of the combustion process and calculating the interesting parameters and the distribution of the mass fraction for the burning by-products. The CFD model was issued for the combustion area and a rich palette of results interesting for any researcher of the process were deduced.

Evaluation of ignition and combustion quality of different formulations of heavy fuel marine oil by laboratory and engine test

C.R.P. Belchior & J.P.V.M. Bueno - COPPE-EP-Federal University of Rio De Janeiro, Rio de Janeiro, Brazil

Abstract

Federal University of Rio de Janeiro installed a laboratory regarding the possibilities of obtaining performance tests of heavy fuel oil in a marine medium speed engine with the aim of improving its ignition quality and combustion properties. The paper describes the facilities, equipments installed, test methodology and obtained results. The fuel is also analyzed in a FIA test instrument and the results compared to those obtained in the engine laboratory. Special concerns are the ignition delay, estimated cetane number, maximum combustion pressure and others variables that defines the fuel ignition quality.

A diagnostic system monitors the combustion and operation cycle of the engine using information such as cylinder pressure versus crank angle, ignition delay, maximum combustion pressure, mean indicated pressure and indicated work. A thermodynamic simulation model of the operation cycle was also developed to compare with the experimental results. The model allows engine performance estimation of different heavy fuel oil compositions.

3D measurements of the effective propeller jet flow behind the rudder

T. Abramowicz-Gerigk - Gdynia Maritime University, Poland

Abstract

The paper presents 3D measurements of the effective velocity field generated by a controllable pitch propeller of a twin propeller twin rudder ferry model in 1:16 scale. The bollard pull tests were performed in the experimental setup situated on the lake. The distribution of the propeller jet velocity behind the rudder, in the zone of flow establishment was investigated. The use of the large physical model allowed studying the effective propeller jet characteristics. The influence of the propeller pitch, rotational speed, aft body form of the ship hull and shallow water effect on the velocity field are discussed.

A new logic for controllable pitch propeller management

F. Balsamo, F. De Luca & C. Pensa - Università degli Studi di Napoli "Federico II", Naples, Italy

Abstract

In this study we want to propose an active logic that, continuously, optimizes the configuration of the propeller and motor speed taking into account changes in resistance and wake.

The working principle of the control system is based on the measurement of the torque absorbed by the propeller and the engine speed, to obtain the actual thrust and advance speed coefficients. Based on these data, the controller identifies the configuration of the propeller for the best performance of the entire propulsion chain, from engine to propeller. Moreover, in addition to

torque and speed limits of the engine, the control system chooses pitch angle taking into consideration the propeller's cavitation.

Exhaust gas waste heat recovery in marine propulsion plants

G. Theotokatos & G. Livanos - Department of Naval Architecture, TEI of Athens, Egaleo, Greece

Abstract

In the present paper, the waste heat recovery (WHR) installations used for the production of saturated steam and electric power for the cases of a two-stroke and a four-stroke engine ship propulsion plant are investigated. The examined waste heat recovery system is considered to be of the single steam pressure type with an external heat exchanger for the heating of feed water entering into the boiler drum. The option of using the engine air cooler for heating the feed water was also examined. The waste heat recovery installation was modeled under steady state conditions and the derived WHR installation parameters for various engine loads are presented and analyzed. Furthermore, using the simulation results, the improvement of energy efficiency design index (EEDI) of a typical merchant ship is calculated and the impact of the WHR on the ship EEDI is discussed.

Mean value modeling and model predictive control of turbocharged diesel engine airpath

Safak C. Karakas & Oguz S. Sogut - Faculty of Naval Architecture and Ocean Engineering, Istanbul Technical University, Istanbul, Turkey - Can Ozsoy - Faculty of Mechanical Engineering, Istanbul Technical University, Istanbul, Turkey

Abstract

This paper reports the results of a study on mean value modeling and model predictive control of a turbocharged Diesel engine airpath. The objective of this study, and also in general the control of Diesel engines, is to increase the usefulness of the electronic engine control units by using effective control strategies, such as model predictive control. The system used in this study consists of a four stroke, four cylinder high speed Diesel engine, a Variable Geometry Turbocharger (VGT) and an Exhaust Gas Recirculation (EGR) system. A controller is designed to control the Mass Air Flow (MAF) and Manifold Absolute Pressure (MAP) by changing the positions of exhaust gas recirculation valve and varying the geometry of turbocharger. Simulations are developed to enable the system work at different setpoints and also to include the effects of disturbances and wrong model order.

1.4 IceFish 2011 – Reykjavik, Iceland

LUMINELL AS – Powerful LED Floodlight

Luminell AS is proud to present the next generation of powerful lighting solutions made for the offshore industry. The RLX-series is "state of the art" LED lighting that settles a new standard for floodlight systems in the extreme environments you find offshore. On the basis of our knowledge of the market, we have developed a series of floodlights that can handle quakes, shakings and change of voltage. The floodlights are adjustable and can be placed at the most critical parts of the vessel to give light under any circumstances. Maximum light is reached few seconds after turning it on, and the number of times switching the light on and off will not affect the lifetime of the product. The powerful, high-quality light provides realistic colors and contrasts, and makes it possible to see small details on deck. The crew will experience a comfortable working light, increased safety and sustained effectivity during operations.

The RLX series is delivered with 8 different beam options which give an optimized light-distribution and thereby makes it possible to minimize light pollution to the surroundings. The wide range of different beams will help engineers to design a highly efficient light solution. The RLX series will make your floodlight-installation save up to 80% in power consumption compared to current technology. RLX increases safety and effectivity on deck, minimizes light pollution to surroundings and reduces maintenance and power consumption.

IBERCISA – Electric winches

The electrical drive on the machines reduces, not only the space needed for installation of the main operation system, but it is also lighter in weight and more efficient giving improved performance on automatic trawl winches. However, these are not the only reasons for favoring an electrically driven system. We should also note the following:

- Lower installation costs as the machine is free of tubes.
- Lower energy consumption, maintenance and noise levels, thereby improving security and operator well being.
- Winch ignition through the alternating current includes a frequency converter, an alternating current motor (AC), a frequency converter on the winch, a refrigeration system for two motors and an energy regeneration system;
- Higher efficiency on the machine (input/output power) and energy regeneration during the free pay out improve vessel's energy consumption quota;
- The efficiency of electric ignition is around 85%-90% as opposed to hydraulic system efficiency that may vary from 50% to 70%;
- Provides better control than hydraulic starting systems with a variable speed control of 2% to 100% of maximum rpm and the whole torque on any rpm level.

- Environmentally friendly
- Extremely silent operation
- No emissions or oil spills / leakages, no risk of fire, no need for oil filters and oil dirties disposing



Figure 5. Electric winches

Compared to hydraulic winches, electric winches can reduce power required for trawling winch because of more energy efficiency (80% for electrical against 55% for hydraulic winches).

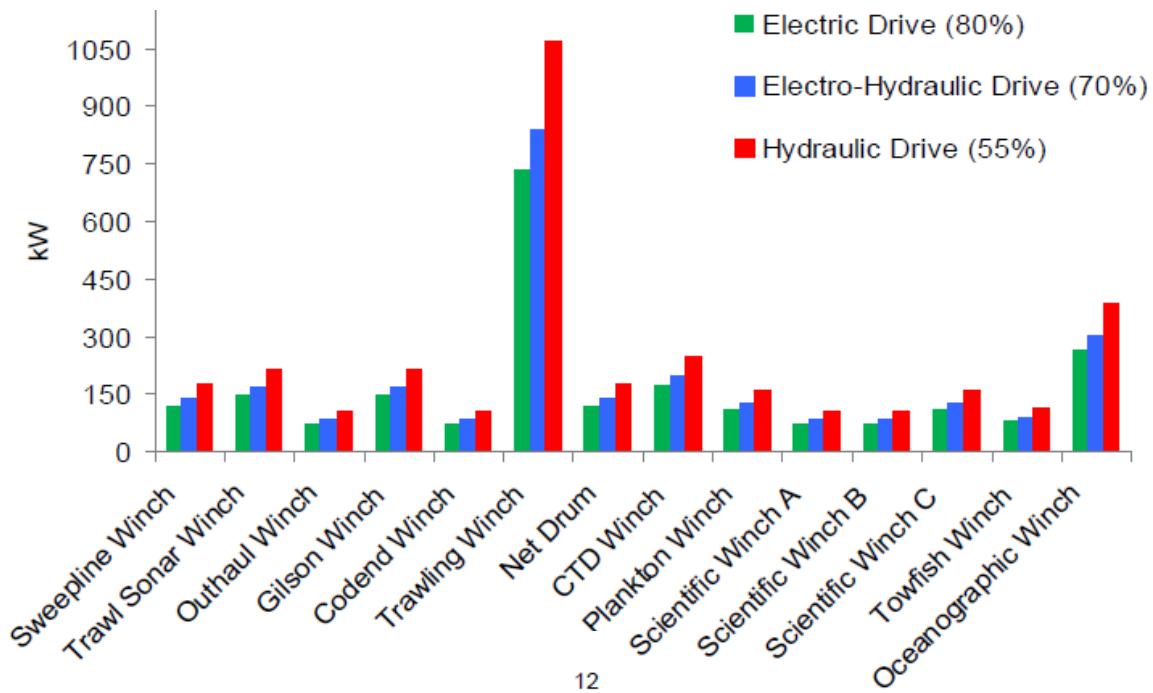

Figure 6. Comparison between hydraulic and electric winches, for different types of winches

Power management possibility:

Electric drive winches can provide better control than hydraulic drive winches.

It is possible to set speed operation from 2% to 100% of maximum rated RPM and full torque at any RPM. Control system allows also automated management during shooting and hauling, controlling also tension and speed.

Energy recovery:

As the trawling winches are moved by warps or by the net, one of the most important characteristics of electric winches is the possibility to recover energy during shooting. The energy recovered depend on the total length of the warps used for each haul and the speed of the vessels.



Figure 7. Electronic drag management

On the top it is possible to read about performance for all the drums; at the same time, the gear drag is measured. On the bottom, the console is showed, controls for the torque (on top on the left) and on the bottom two sticks for the shooting or hauling of the ropes.

VAN BEELEN – Dyneema

The Dyneema® fiber is a gel-spun, multi-filament fiber produced from ultra high molecular weight polyethylene (UHMW-PE), with main characteristics: high strength, low density, low elongation at break, and resistance to most chemicals. To stimulate developments, this sheet provides an overview of properties measured on Dyneema fibers. The disclosed data is not valid for any other source of high-modulus polyethylene fibers.

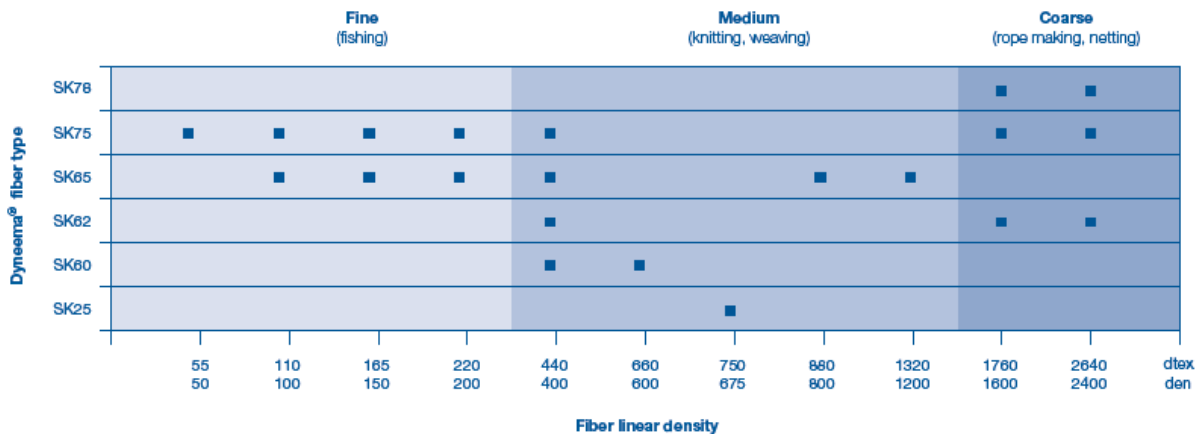

Figure 8. Performances of Dyneema ropes

Dyneema fibers feel smooth due to their low friction coefficient. Its low density enables it to float on water. The water absorption in the fiber is negligible. Dyneema fibers are visually opaque. The fiber is invisible to an UV-light source due to the low UV absorption coefficient in combination with no fluorescence or phosphorescence. It is also invisible for thermal imaging devices because of its low IR absorption coefficient and high thermal conductivity. The low reflectivity of radar waves results in a high transparency for radar sources. The refractive index axial to the fiber axis differs from the transverse direction making the fiber perform birefringence.

POLY – ICE TRAWL DOORS - pelagic trawl doors

As a trawl door is towed through water, a patch of turbulence forms behind it that pulls constantly against the direction of the tow and this turbulence forms a large part of a trawl door's drag. Hampidjan's aim was to reduce drag and the conclusion was to add these ventilated slats, essentially forcing the turbulence into a constant flow behind the door. This has improved lift, which the company refers to as the door's squaring power, by as much as 20%, depending on the towing speed. The doors also have better stability with a more constant relationship between the warps, doors and the trawl while towing, as well as in shooting and hauling and when taking a turn.



Figure 9. Energy efficient Poly – ICE trawl doors

DYNEX WARPS

The Dynex Warps are made with a thread of lead inside a plastic core, which is heat sealed. When heated it is forced outwards and bonds with the Dynex Warp itself. To protect from abrasion the Dynex Warps are overbraided with a thick and durable cover of Dyneema.

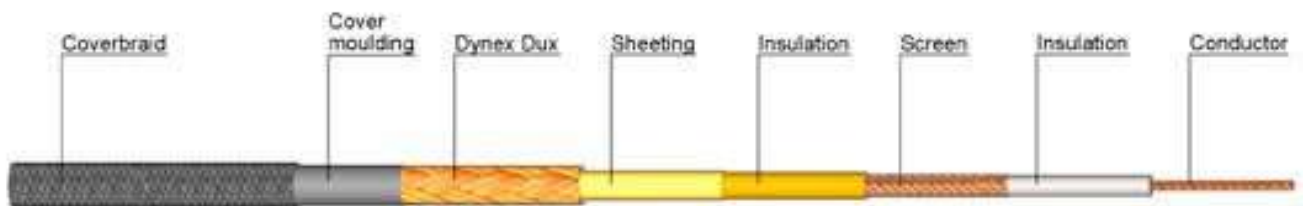

Figure 10. Dynex warps

Less energy is needed to tow light weight warps. Same spread can be achieved with smaller doors or less angle of doors. Less weight keeps the trawler higher in the water and towing and steaming resistance is less. Less abrasion on blocks. Less abrasion on wire guiders. Less scratching of inner winch drum flanges. No lubrication of warp needed. Dynex Warps are spliceable and easy to

handle. Birkeland's owners are in line for a subsidy from the Norwegian NOx fund to purchase Dynex Warps to reduce the vessel's displacement and, at the same time, reducing its emissions of noxious gases. The difference in weight between conventional and Dynex Warps is 22 tonnes, as the normal 38mm steel wire rope warps weigh in the region of 26 tonnes, which allows Birkeland to ride higher in the water. The predicted reduction in greenhouse gases due to this is put at 120 tonnes annually.

1.5 DanFish 2011 –Aalborg, Denmark

ROLLS ROYCE

New electric hybrid propulsion system

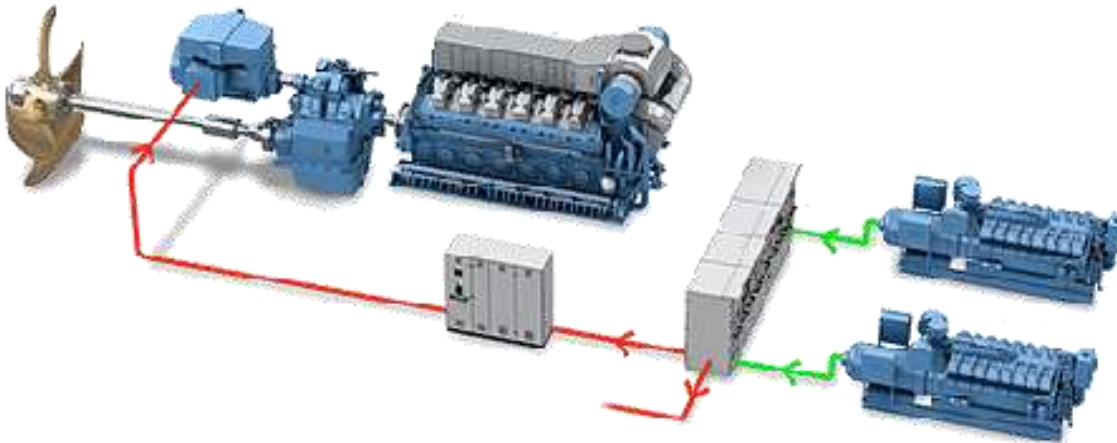

Figure 11. Rolls Royce Propulsion system layout

A new propulsion system layout is proposed by Rolls Royce. Compared to the traditional propulsion system with a main engine coupled with the propeller through a reduction gear, also a shaft power generator is coupled to the main engine through the reduction gear, while few auxiliary power engines are installed for electric power generation. An electronic control system manage the total amount of power requested and the best configuration for the minimization of the fuel consumption.

The HSG (hybrid shaft generator) system is actually an advanced power electric system for conditioning the power coming from a shaft generator so that the switchboard see a constant voltage and frequency, and the correct phase angle to match other generator sets running in parallel. This opens the way for much more flexible uses of engine and propeller speed variations to maximize both propeller and engine efficiencies by running them at their design points. Doing so also helps to reduce exhaust CO₂ and NO_x emissions.

The HSG drive supplies fixed frequency to the switchboard even when engine rpm varies. It also allows SG to operate in parallel with auxiliary gensets. The shaft generator can function either as a generator or as a motor. The HSG allows the propulsion system to be optimized, reducing fuel consumption and emissions in all modes.

The aim of this new system is to expand the range of efficiency of the main engine and the propeller.

Several configurations are available, depending on the power request. So that The HSG concept is suitable for **offshore, merchant** and **fishing** vessels.

Boost mode

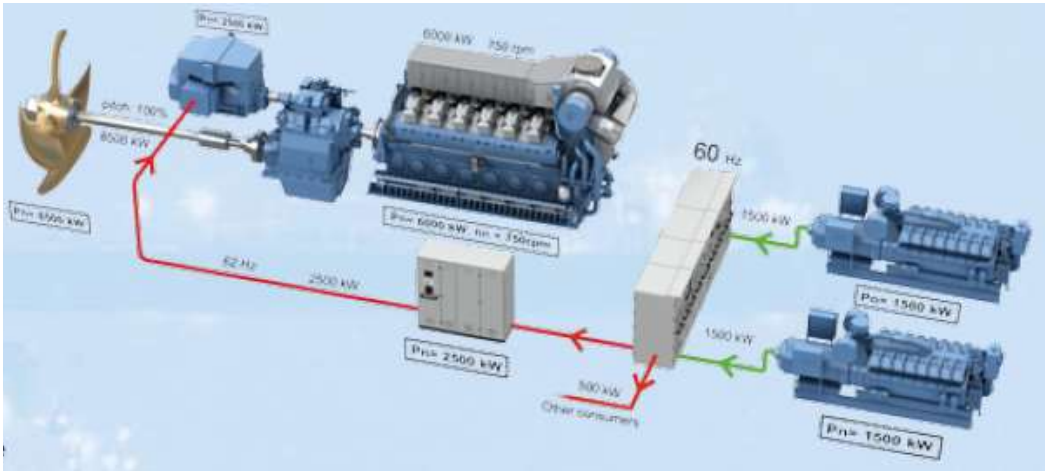

Figure 12. Propulsion system in boost mode: main engine and auxiliary generators deliver power to the propeller to reach the maximum speed

This mode is selected for maximum speed and harnesses most of the ship's power, including output from the auxiliary generator sets for propulsion. The shaft generator is operating as a motor and the output is summed with the main engine power.

Diesel-electric mode

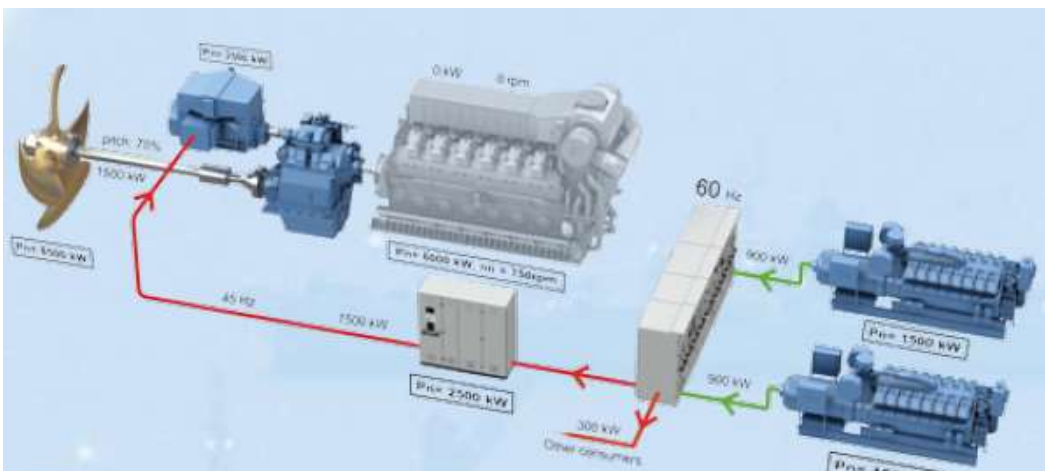

Figure 13. Propulsion system in diesel – electric mode: main engine is switch off and auxiliary engines provide power to the propeller and to other users

When the main engine power is not required, only auxiliary generators run, providing the right power. Electric power for different users and if needed mechanical power for the propulsions through the shaft generator/motor are available.

Parallel mode

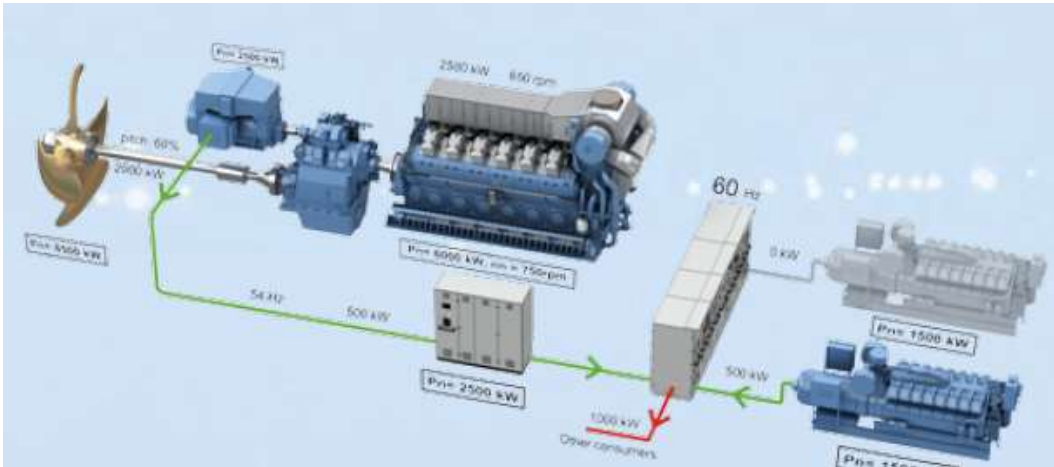

Figure 14. Propulsion system in parallel mode: one auxiliary engine is operating for propulsion and other electric users

The power required for propulsion and hotel loads exceeds that available from the generator sets alone. With the main engine running at around half power, and variable rpm to optimize propeller efficiency, the shaft generator provides the power requested into the electrical system in parallel with one auxiliary generator. The HSG system keeps the frequency fixed.

Transit mode

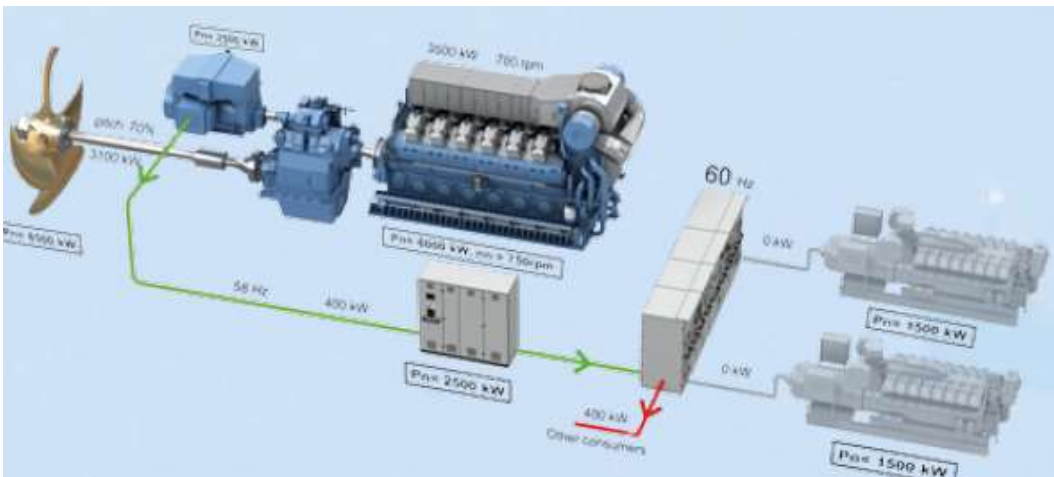

Figure 15. Propulsion system in transit mode: at partial loads, main engine provide power request

This mode is a new setting available with the HSG upgrade, and is used to optimize propeller efficiency for the required speed. It allows the main engine to run at variable speed with the shaft generator supplying the ship's electrical needs. Therefore, both auxiliary generators can be shut off.

MAN

The new VBS Mk 5 version of the Alpha Controllable Pitch Propellers is designed to propel a wide range of different ship types with CP Propellers – customized to match their individual operational requirements, power modes and optimizing points. The new VBS Mk 5 generation consists of a complete range – a total of 20 new hub sizes, which are handling outputs from 1,000 and up to 40,000 kW. The new range spans from hub diameters of 600 mm and up to 2,150 mm – distributed on three series designs: S (small, 600-940 mm), M (medium, 1,020-1,550 mm) and L (large, 1,640-2,150 mm).



Figure 16. MAN Diesel & Turbo presents a new high-efficient VBS propeller generation .

The major benefit of the VBS Mk 5 propeller is an increased efficiency of up to 2%. The operational advantages of increased propeller efficiency are translated into savings via lower fuel consumption and reduced exhaust gas emissions. The increased efficiency may alternatively be exploited as higher thrust for increased ship speed or higher bollard pull for a given engine power.

The shape of the new hub is flow-optimized at its after part and reduced in size – resulting in a lower hub/propeller diameter ratio and a reduced drag. The flow optimization includes a new and more streamlined shape of the hub and blade foot integration, resulting in a blade foot, which is completely flush with the hub contour.

The optimized hub/blade interface allows for higher propulsion power densities. Higher cavitation inception speed is allowed for the propelling of high-speed vessels. A reduced risk of root cavitation permits higher blade loading for demanding propulsion applications.

Propeller blades can be exchanged inside a propeller nozzle, without pulling the shaft. Hub is completely serviceable with the propeller installed. No need for shaft/coupling flange dismantling, shaft pulling and removal of the rudder. It is possible to check/inspection and replacement of internal parts without removing the propeller blades. Hub bearing surfaces are exchangeable. The hub and shaft flange connection is designed for easy inspection during docking and survey. Maintenance concepts for hub wearing parts are available. Underwater exchange of propeller blades is possible.

GENERGI Hydraulic driven generators

Fishing vessels are often equipped with electric generators coupled directly with main engine through pulley transmissions. So that electric parameters are not fixed due to the variability of rpm of the main engine. To improve efficiency and save fuel there are two possibility:

- 1) Use an auxiliary engine as a power supply generator, at a fixed rpm, coupled with an electric generator.
- 2) Use hydraulic systems to generate electric power.
- 3)



Figure 17. GENERGI system; on the left the main engine, on the right the hydraulic pump connected to a distribution header. On the top the electronic system control the operating point of the pump on the basis of the hydraulic power request

GENERGI is an hydraulic driven generator. The main engine provides mechanical power to an hydraulic pump. An electronic system controls pressure and flow rate of the hydraulic oil to

maintain the electric generator at an optimal operational point. Depending on the electric power requested electronic system manages hydraulic oil flow and pressure to assess the right hydraulic power. So that the main engine is never overloaded, providing every time the right mechanical power, saving fuel. The system has been tested on board Norwegian and international vessels over a prolonged period.

During the sea trial on Lake Washington a substantial reduction of the fuel consumption has been measured, when the system was engaged. With two 25 HP fish hold circulation pumps running in addition to other smaller electrical loads, the achieved fuel saving was 5 to 6 GPH (GPH = 3.785 liters per hour) compared with Main Engine / Diesel Generator operating mode.

With the system engaged the fuel consumption of the main engine increased only a small fraction (in the range of 0.1 to 0.3 GPH). The fuel consumption was measured by highly accurate turbine type differential flow meters supplied by Flo Scan Instrument CO., Inc. Separate meters were installed for the main engine and diesel generator.

By eliminating the need for an auxiliary engine to run the vessel’s electrical system, the fuel savings achieved with the system are quite substantial. Furthermore, another huge benefit is the reduction of NOx emission by 45 to 50%. Customers have the potential of saving thousands of dollars in fuel costs and reducing emissions by incorporating your product into their operation.

From the test results, a payback period of 2 years was achieved.

The table below shows an example of savings as a result of reduced fuel consumption and maintenance costs. As a result, environmentally harmful emissions of CO2 and NOx are also reduced.

EXAMPLE BASED ON MEASURES MADE BY FLO SCAN INSTRUMENT		FLO SCAN
A	Number of hours/days	24
B	Operating days per year	200
C= A*B	Operating hours per year	4 800
D	Diesel NDK per litre	3,00
E	Kg CO2 per litre	2,68
F	Kg NOx per litre	0,007
G	Reduced diesel consumption per hour	17
H= C*F*G	Reduced emissions in kg NOx per year	548
I= C*E*G	Reduced emissions in kg CO2 per year	219 080
J= C*D*G	Reduced fuel costs in NDK per year	244 800
K	Reduced maintenance costs, auxiliary engine (5-10 NDK/hr)	35 200
L= J+K	Reduced operating expenses in NDK per year	280 000

It could be useful to note that if the electric power onboard is stable and of good quality (fixed frequency and voltage) many electric users could be included, for example, electric winches. On the other hand, when hydraulic power is needed onboard, it is necessary to provide another hydraulic power pipe line, with other hydraulic pumps.

DESMI

The cooling system of the main engine could be improved through an automatic control system. Normally cooling water pumps are driven by main engine through pulleys. They are designed for the maximum capacity and run at a speed related to the main engine speed. The more the engine speed rises up, the more the pumps speed increases. This is a secure and easy system, but it is not efficient from the point of view of the energy consumption. The flow rate of the cooling liquid is often more than the needed.

Optisave is a control system kit that allows to manage cooling system electric pumps. This system can control and evaluate the right flow rate needed, depending on the main engine temperature and the sea water temperature. Through sensors applied along the cooling circuit, electric pumps are managed and the right electric power is delivered, reducing energy waste.

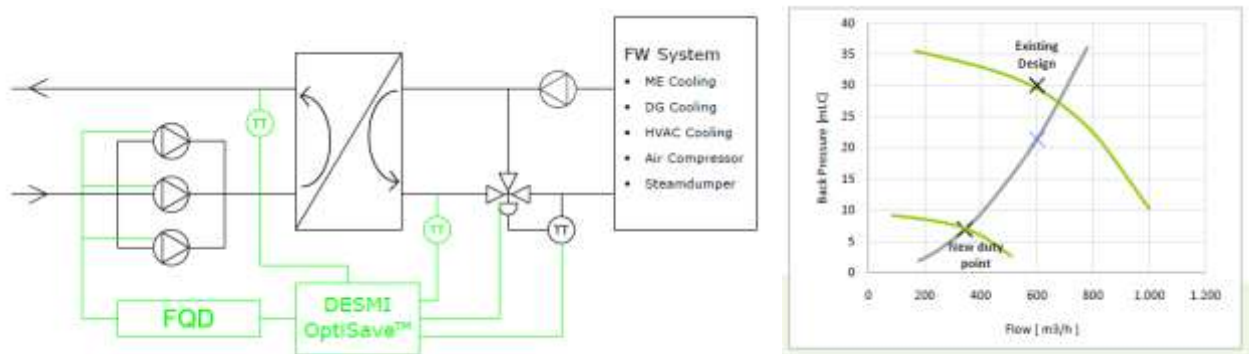

Figure 18. OPTISAVE management system; on the left the layout of the Optisave system shows pumps controlled as well as the three way valve of the main engine cooling system supply.

As shown in the picture the Optisave system controls pumps speed to the current conditions. It also controls a three-way valve for the management of the cooling fluid in the main engine. The savings obtained in recent case studies are about 80%, maintaining the cooling system efficient without problems for the main engine on the basis of the previous system based on pulley driven pumps. The payback period was about one year.

Energy Reductions in Fishing Vessels

From 2009 to 2010 many energy audit onboard fishing vessels were carried out.

2009

Number of vessels	Total fuel consumption in liter (Marine diesel 0,1 % sulphur)	Average in savings (if performed)	Total fuel saving in liter.	Total gross Tons	Accumulated engine power (kW)
112	39,752,220	*13.4 %	*5,326,795	22,895	53,298

2010

Number of vessels	Total fuel consumption in liter (Marine diesel 0,1 % sulphur)	Average in savings (if performed)	Total fuel saving in liter	Total gross Tons	Accumulated engine power (kW)
49	21,578,000	*13.9 %	*2,999,342	10,603	30,258

As a result of energy audit carried out, some areas where energy saving could be achieved are shown.

Propulsion system



Figure 19. Propeller and propeller nozzle before and after change

The case study of a purse seine is reported. After preliminary energy evaluations, owner decided to change propeller and propeller nozzle with new more efficient. As a result, the bollard pull increased from 19.1 tons to 23.6 tons.

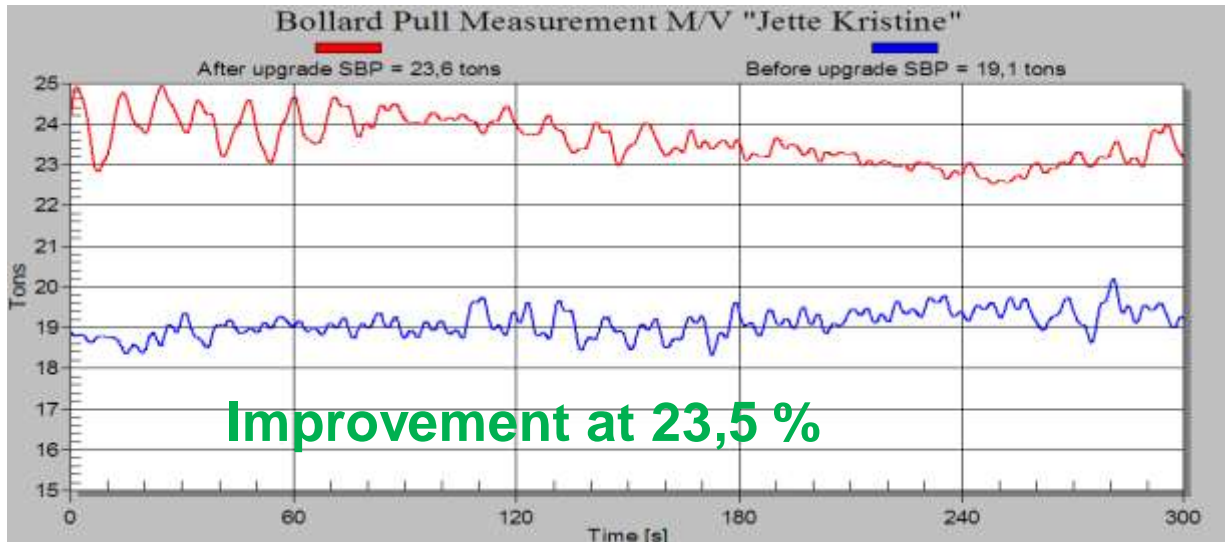

Figure 20. Bollard pull before (in blue) and after (in red) change

Latest information from the vessel indicates a fuel saving at minimum 15 %. The vessel consumes approx. 600,000 liter of MGO per year. The total savings at approx. 90,000 liter MGO at approx. 5,- DKK per liter = 450,000 DKK / year (60,466 Euro).

Hydraulics:

The total amount of fuel consumption related to hydraulic users is about 11%.

Hydraulic is used for most power transmissions, trawl winches, net drums, cranes, anchors, winches, rudder hydraulics.

Areas in which energy could be saved are in frequency regulating of hydraulic pumps and on/off switch near operation areas.

Refrigeration:

Refrigeration represent approx. 7% of total fuel consumption.

It is possible to save fuel using:

- Energy saving compressor
- Frequency control on pumps
- Automatic regulating systems on RSW valves
- Insulation of cargo holds

Related to insulation, pictures below show how it is important to take care to the design of the vessel.

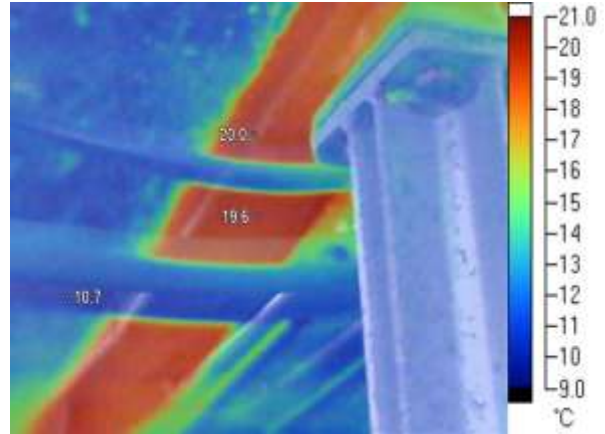

Figure 21. Thermo graphic analysis

The heating pipes were running from the engine room to a heating ventilator in the forecastle, inside the aluminum deck support. This reduces the effect of the ventilator and heats up the cargo holds. It was recommended to insulate the pipes.

Heating:

Refrigeration represent 2% of total fuel consumption.

When using the waste heat from the engines the ships' efficiency is improved. The price from an oil boiler is approx. ¼ per produced kWh compared to electric heating (DKK prices). Electric heating approx. 0.28 €/kWh - Oil heating 0.08 €/kWh

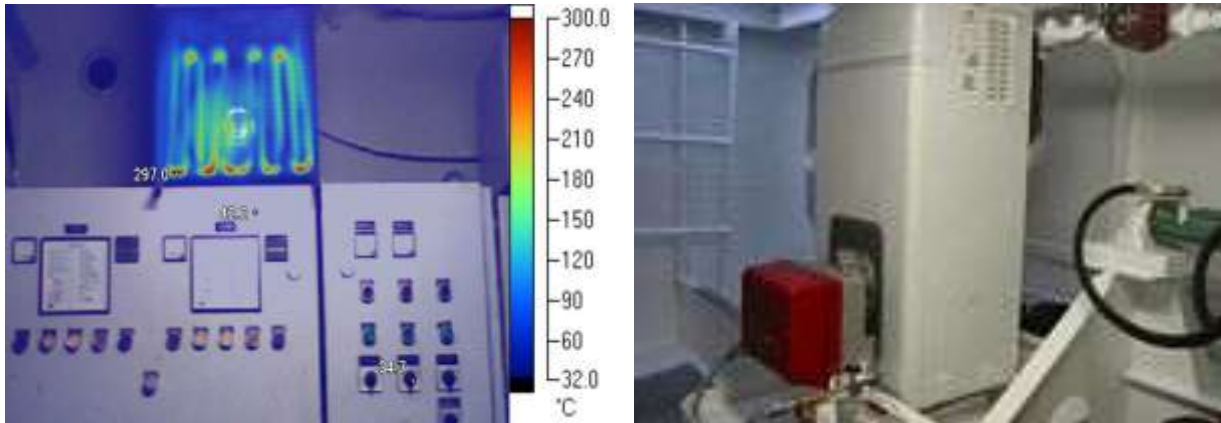

Figure 22. Heat exchangers for electric users (on the left) and hydraulic users (on the right) are connected with the cooling system of the main engine; this heat could be recovered and used for heating rooms.

Electricity and lighting:

It represent 3% of total fuel consumption. It is better to product electricity with smaller gensets, using new gensets, with improved efficiency.



Figure 23. The fuel consumption of the lighting largely depends on the fishing techniques and activities onboard.

Main engine

Approx. 40% of the fuel are is for propulsion, the rest disappears into different losses (flue gasses, cooling water, mechanical loss) Improvements could be obtained for example using waste heat from cooling water system, new electronic controlled – more efficient engines; savings obtainable are around 10 – 20 %. Moreover, the best and easy way to save fuel is Slow down.



Figure 24. Diesel engine before installation – engine room

Bulbous bow

Reduces/changes the waves in front of the ship. At high speed this appendage is most efficient savings up till 30 %. It is important a correct design; at a lower speeds the total resistance of the hull is increased so that the fuel consumption. A bulbous bow must be included when the vessel needs to reach high speeds.

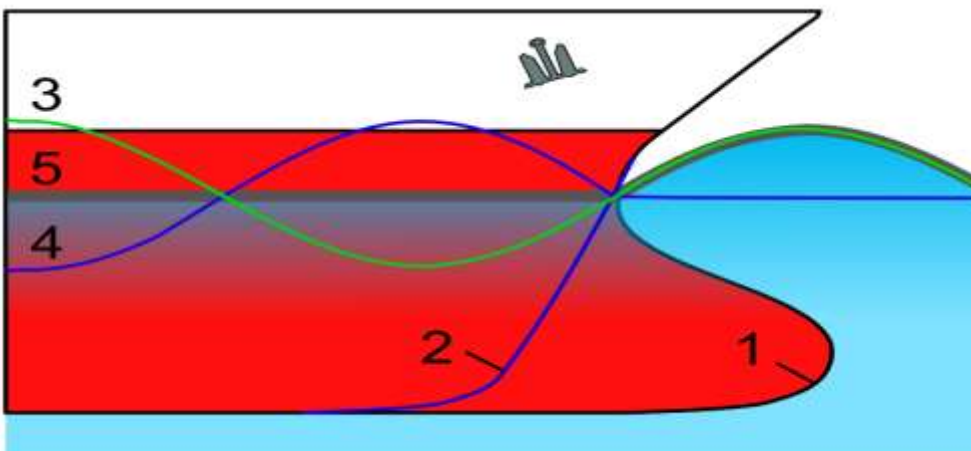

Figure 25. Blue line represent the hull without bulbous bow and the wave generated. The green line represents the wave with a bulbous bow

Optimizing fuel consumption

V. Mogens Christensen – CEO at Hundested Propeller A/S

The propulsion system is the more energy intense user. A lot of fuel could be saved taking under control the right operating of the propulsion system.

Optimizing the propulsion system for fishing, can be done by adjusting a few factors:

- Lower the propeller speed
- Increase the propeller diameter
- Mounting a nozzle
- Optimizing of the water flow to the propeller

The technical parameter for a correct design of the propeller are:

- Diameter
- Thrust
- Revolution speed
- Service speed of the vessel
- Pitch
- Projected area

On the basis of the propulsion system requirements, changing these parameters is necessary to obtain the correct thrust and vessel speed.

Input for a correct design are power requested by the hull for the design speed, proper thrust for trawling fishing gear or if a certain bollard pull is needed. The propeller diameter can be optimized from a given input power and gear reduction or propeller speed can be optimized from a given input power and propeller diameter. Optimizing the propeller design, input power can be optimized/minimized for a specified bollard pull.

Propeller size

A large propeller diameter increases bollard pull and efficiency. The propeller speed is adjusted to the diameter. The more the diameter is big the more the revolution speed of the propeller decreases, for the same thrust; considering that typical marine diesel engines have almost constant torque in all the range of revolution speed, decreasing revolution speed of the propeller means decreasing the revolution speed of the engine, so that the power delivered to the propeller.

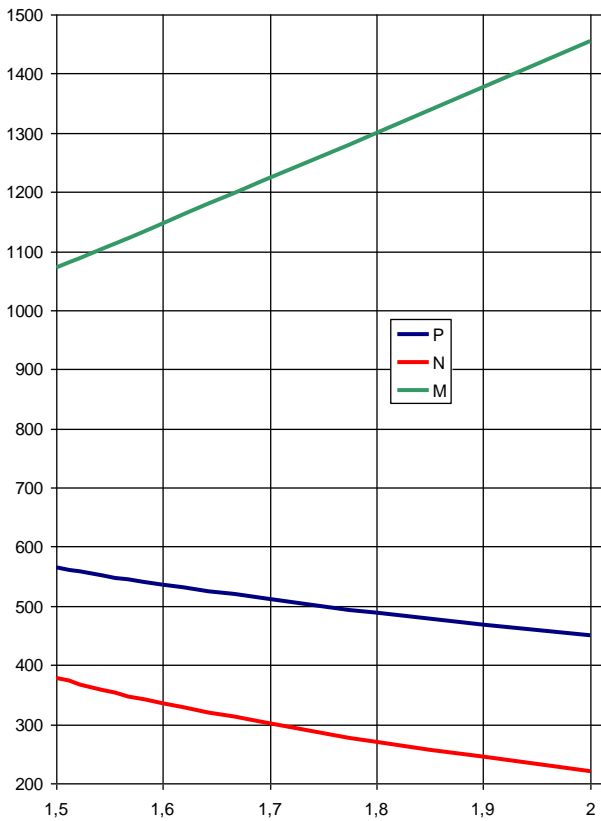

Figure 26. Power request (in blue) torque (in green) propeller devolution speed (in red) against propeller diameter

Number of blades

From experiments conducted is learned that the efficiency of the propeller decreases with increasing number of blades, as shown below:

Number of blades	2	3	4	5	6
Efficiency	0,765	0,720	0,718	0,656	0,555

On the other hand a greater number of blades is useful for a more uniform torque transmitted from the engine, providing also a smoother propulsion, this is due to smaller pressure impulse per blade, but it is not convenient to adopt propeller with an excessive number of blades because it would be very costly.

Bollard pull for a nozzle propeller @460 HP

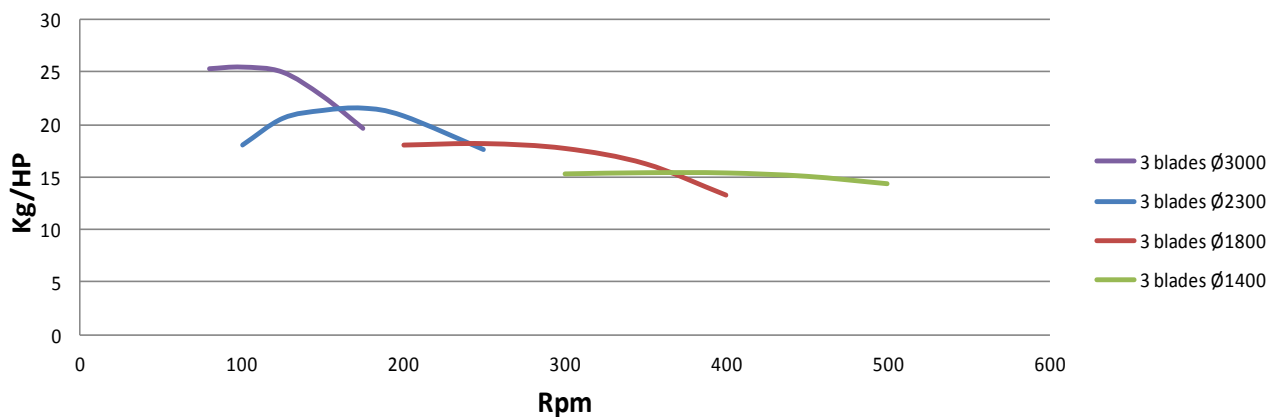

Figure 27. Comparison between propellers with different diameter for the evaluation of the propeller thrust

Nozzles

The use of ducted propeller increases the propeller thrust for a given diameter. The nozzle increase increased flow to the propeller. So that the propulsion thrust is Increased for the same diameter at low speeds of up to 20-30%.

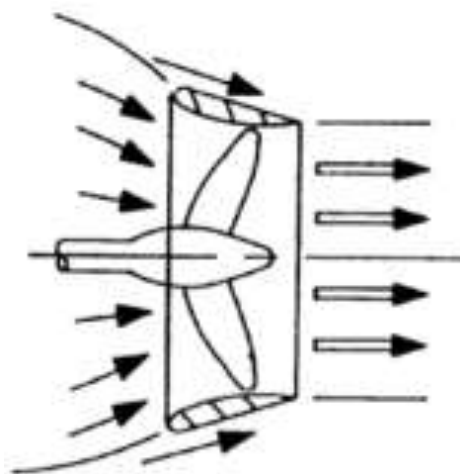

Figure 28. Water flow is increase thanks to the hydrodynamic performance of the nozzle

On the other hand, when an high vessel speed is requested, the nozzle increases the hull resistance, so it is necessary to evaluate exactly the vessel speed desired to choose the right propeller type, as shown in figure below.

Propeller thrust with and without nozzle

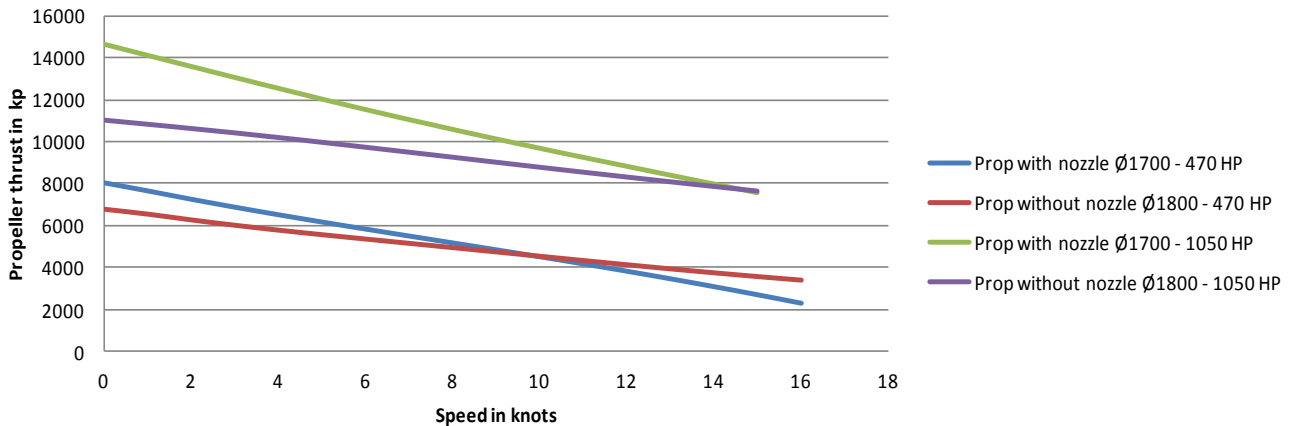

Figure 29. Differences between ducted and no ducted propellers

Flow to the propeller and hull design

Wake fields determine the propeller design. Wake fields are made according to the “naked” hull. External equipment can influence the wake field, as for example pipes for cooling, bilge keel, water inlets and sensors for instruments, anodes.

External equipment placed incorrect can disturb the flow of the water to the propeller and the propeller efficiency will drop rapidly. If the aft ship is too wide, separation may occur, as shown in the pictures below.



Figure 30. Cooling system is in a wrong position, disturbing water flow through the ducted propeller; efficiency of the propeller decreases quickly.



Figure 31. Modifying position of the cooling system efficiency of the propeller increase.

Comments

Possibilities to minimize fuel consumption

- New gear with a larger reduction ratio
- New bigger propeller
- Installing a nozzle or a bigger nozzle
- Change the shaft angle or lower the stern tube to make room for a larger propeller diameter
- Change the aft body to avoid separation
- Check appendixes like keel cooler, anodes etc

It is a must always to install a nozzle on a trawler. The choice of a fixed/rudder nozzle is not as important as a good water inflow. The angle of the nozzle should be perpendicular to the water inflow. How the water flow acts after the nozzle is not important. The mounting bracket for the nozzle should be as small as possible. Oval shaped is preferred. Cooling pipes/keel cooler to be placed with respect to water inflow to the propeller. Bilge keels should follow the water flow.

BEEP – A demonstration project

The project BEEP Balti Energy Efficiency Project, is a demonstration project on energy efficient trawl gears. It is financed by the Ministry of Food, Agriculture and Fisheries and the European Fisheries Fund.

The main goal of this project is to show what is obtainable in terms of catch and energy efficiency by using the best available technology. Preliminary results of the project show that the catch per hour can be increased by 20% and the energy consumption reduced by 10% per trawling hour.

Partners of this project are:

- F/V "Katrine Kim", skipper Niels Jørgen Nielsen
- Bornholm and Christiansø Fishermens Association, project holder
- DTU-Aqua
- A Espersen AS
- Gemba Seafood Consulting AS, project leader
- Teknologisk Institut
- Thyborøn Trawl Doors
- Nexø Vodbinderi
- CATch-Fish

It is known that energy efficiency is related to the fuel consumption. So that, increasing energy efficiency means to increase profit. Furthermore environmental aspects must be considered.

Improving energy efficiency enables to use larger fishing gear, increasing catches per hour, so that spending less time at sea and increasing also quality of the fish landed because of the less time between the catch and the landing.

Materials

For the development of this project, best technologies were adopted for the fishing gears, the fuel consumption evaluation etc.

In particular, Dyneema materials were used for the net, except for codend; T90 knots in belly sections and in the codend were used.

Thyborøn otter boards were used for the bottom trawling and Simrad gear monitoring system for the real time evaluation of the geometrical parameters of the net.

The importance of the behavior

The drag resistance of the fishing gear affects fuel consumption. Drag resistance is related to vessel speed, projected area and gear shape. $Drag = \frac{1}{2} \cdot \rho \cdot A \cdot C_D \cdot V^2$

The reduction of the drag resistance calls for making less projected area, changing shape to reduce body coefficient and, mainly for reducing vessel's speed as much as possible.

The resistance of the trawl doors is also influent in the overall gear drag. New more efficient trawl doors like Thyboron which are flying otter boards, can reduce fuel consumption up to 15% and at the same time increase door spread by 15%.

Preliminary results

The project shows that fuel consumption per kg of cod can be reduced by 35%. The reduction of fuel consumption per kg of catch consists of an increase in the catch per trawling hour of 20% and a reduction of fuel consumption per trawling hour by 10%.

Economic effect

As mentioned above, the annual catch can be increased by 20% without increasing number of trawling hours. The fishing vessel used for tests has a catch quota of 300 t with the traditional fishing gear. With the new fishing gears, it has increased his quota up to 360 t. considering that the value of the catch is around 8 DKK/kg, it is possible to calculate as below:

Catch quota (with traditional fishing gear)	300 t	total value	2'400'000	DKK
Catch quota (with new fishing gear)	360 t	total value	2'880'000	DKK
Increase:			480'000	DKK
Simrad sonar equipment			150'000	DKK
New trawls			120'000	DKK
New trawl doors			80'000	DKK
Dyneema rope			40'000	DKK
Total			390'000	DKK

The payback period is of one year and considering that investments have a 5 years estimated life, the investment will exceed 300% p.a.

It is possible to assess that only with improvements in cod catch investments are covered. It must be also considered benefits related to other targets using the new fishing gear.

1.6 DeMaT' 2011 –Split

About “DeMaT’2011 – Methods for the Development and Evaluation of Maritime Technologies”

The peculiarity of this DEMaT workshop lies in promoting not only the necessary scientific exchange between single partners but also in integrating students already at an early stage in this international community of engineers and scientists. For the fishing engineers mathematical modeling, numerical analysis or model experiment must be seen as natural tools in the analysis and development of fishing gears today. FEM analyses and CFD simulations are by no means foreign words. Computer simulations can help scientists and engineers to maximize analysis results of new developments and innovative solutions saving time and money for experimental trials. Due to the complexity of model that must be studied, an important development of new software is requested. In many papers presented at this conference, fishing new fishing gear dynamic analysis were carried out. Also environmental impact of fishing gear could be represented in a modeling software and further suggestions to the right gear development are obtained.

Modeling gear seabed interaction during demersal trawling - design study

A.J. BEVERIDGE, F.G. O’NEILL - *Marine Scotland Science, Marine Laboratory, Aberdeen, AB11 9DB, Scotland*

Introduction

The interaction between gear components and the seabed in a demersal trawl is important in working towards a sustainable fishing effort. Contact with the seabed is necessary in targeting certain species. Excessive contact, however, can damage benthic habitats and increase the drag of the fishing gear, **increasing fuel consumption**.

Understanding the interaction between the trawl gear components and the seabed can suggest changes in design and operation that can lead to a more sustainable practice; reducing both damage to the benthic habitat and fuel cost.

A numerical model has been developed that allows the detailed interaction of fishing gear components and the seabed to be studied. The model utilises the engineering simulations package ABAQUS and a Coupled Eulerian - Lagrangian (CEL) method. This has been used to study the drag performance of discs; discs being a common shape used in the ground gear and roller clump of demersal trawls.

Drag performance refers to the horizontal drag force and vertical penetration into the seabed by the disc. Empirical relationships have been developed that relate the drag performance of discs to the input parameters of the model. These empirical relationships suggest design and operational changes. This is demonstrated in a design study that shows that increasing the radius of contact,

with the seabed, will have a beneficial increase in the drag performance; reducing the penetration and horizontal drag force.

FEM analysis of seabed – disc interaction

The interaction between gear components and the seabed is one of the relevant parts of the drag resistance. It could represent 17% to the 40% of the total drag resistance. It is important to reduce gear drag to reduce energy consumption during fishing.

The results for horizontal reaction force and sinkage are averages over the period where the applied vertical load remained constant. A von Mises stress plot can be seen in Figure 32. Note the berm forming at the lead face of the disc.

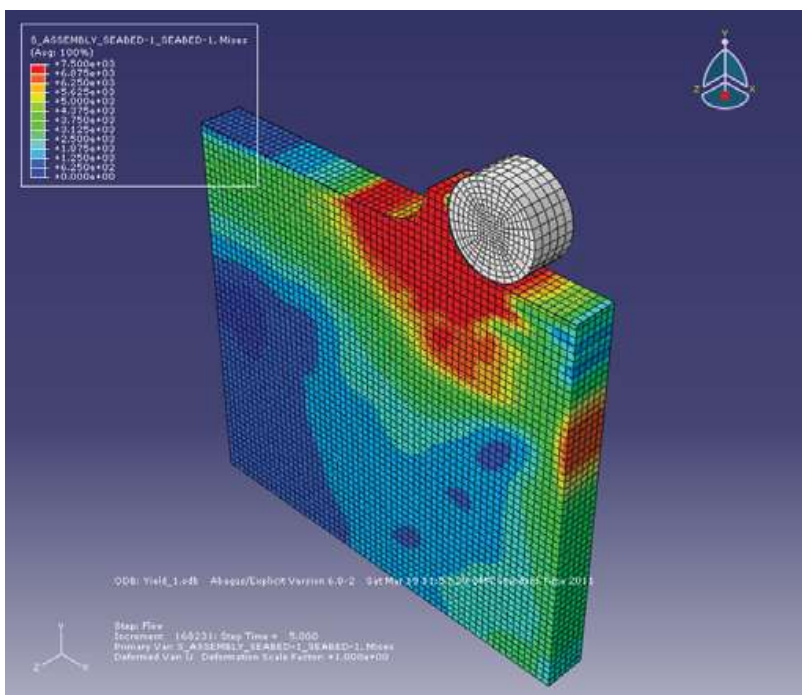

Figure 32. Horizontal reaction force

Shape optimization for dragged object

Starting from this simulation, it is possible to suggest some improvement on the basis of the relations between geometrical parameters and performances results by the FEM simulations.

So that other another disc and a NACA 0025 profile has been tested. This is to show what savings in pelodynamic can be made by changing the shape of the dragged object.

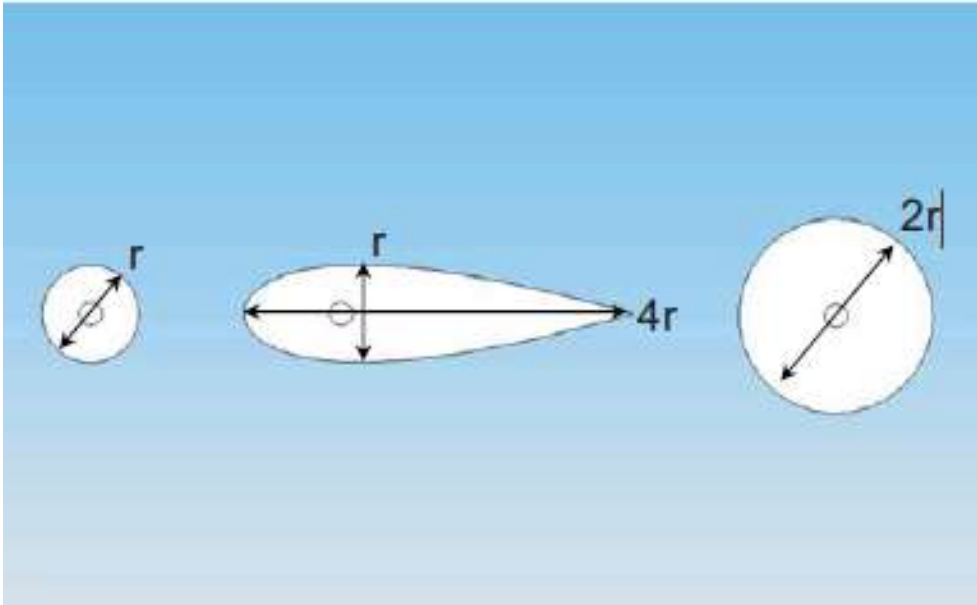

Figure 33. Various shapes for reduced horizontal drag.

Results of different simulations are showed in Table 4. It is possible to note that, from the point of view of the drag resistance, it could be better to increase radius of the disc, because of a reduction in sinkage.

Table 4. Maximum sinkage and average horizontal drag force for various shapes.

Shape	Maximum s (m)	F_H (N)
r	0.21	12'878.13
2r	0.13	5'941.20
NACA0025	0.08	1'906.27

If the radius is doubled then it:

- Reduced the sinkage by approx. 40%
- Reduced the pelodynamic drag by approx. 50%

At sea, however, the drag process takes place underwater and therefore the hydrodynamic load should also be a consideration. In this case doubling the radius increased the fluid drag by approx. 100%. If the aerofoil is used instead then it:

- Reduced the sinkage by approx. 60%
- Reduced the pelodynamic drag by approx. 85%
- Reduced the hydrodynamic drag by approx 90%

The aerofoil reduces sinkage further by having an even greater contact radius than the disc of $2r$. Therefore the aerofoil shape has benefits for both the pelodynamic drag and the hydrodynamic drag. This brief design exercise shows that changing the shape of the dragged object can have a noticeable effects upon the drag forces experienced. With the aerofoil shape showing promise in the simulations it can be envisaged that fishing gear components could be modified to incorporate aerofoil shaped elements.

Conclusions

This work has shown the aptitude of the CEL method to large deformation problems over the classical finite element approach, offering increased accuracy and computational savings. A non-dimensional parameter has been extracted from a governing equation that allows the rescaling of the problem and the possible creation of empirical rules around this parameter that can predict the penetration and pelodynamic drag for given input parameters. With the CEL modeling approach it has been possible to show that increasing the radius of contact with the seabed reduces the sinkage and therefore the pelodynamic drag. This opens the way for introducing aerofoil shaped components into the trawl system for both the reduction in hydrodynamic and pelodynamic drag.

Contact forces between seabed and fishing gear components

BIRGER ENERHAUG - *Senior Scientist, SINTEF Fisheries and Aquaculture, Trondheim, Norway*

Introduction

High fuel prices and environmental issues have initiated quests for more energy friendly fishing methods and ways of reducing the emission rates in the fishing fleet. Bottom trawls is still the most common, and energy consuming type of fishing gear. For this type of fishing gear, as well as other types with bottom contact, the contact forces between gear elements and seabed have a significant influence on both resistance and shape.

To increase the basic knowledge on this topic, and to improve the accuracy of our computer programs and advisory ability, a series of model tests were carried out as a part of a 4-year research program at SINTEF in Norway. In this study the contact forces between a fine, uniformly graded sand and scale models (1:5) of short and long linked chains, rope, rock-hopper and bobbins were measured at different angles of attack and speeds. Tests were done in both dry sand and at various water depths.

Experimental set-up

The tank/basin used for the experiments were originally designed and built for testing the holding capacity of anchors in relation to a master study. The tank was built inside a flow channel at the Coast and Harbour Laboratory in Trondheim, and had a total length of 14 m, a width of 0.8 m and a sand depth varying from 1.0 m at the deepest part to, 0.15 m at the shallowest part (Figure 34).

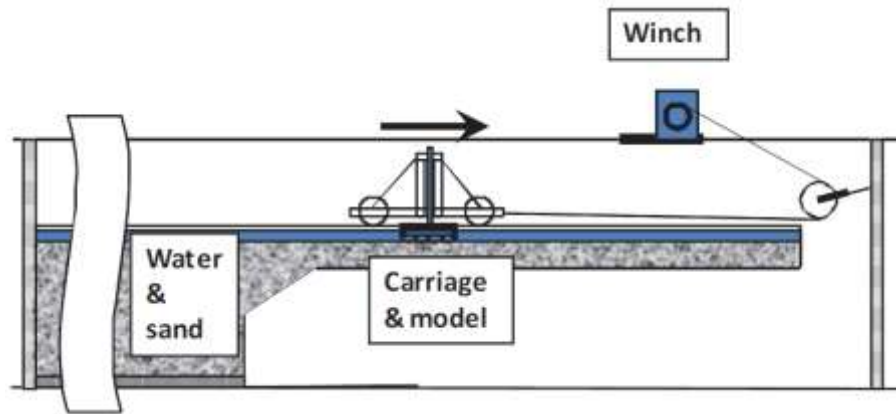
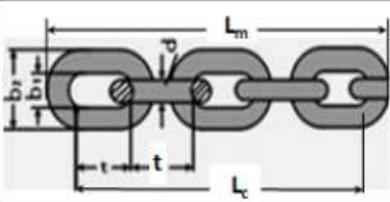
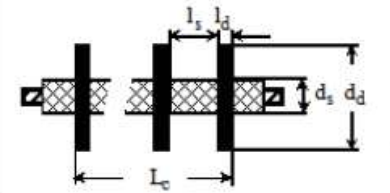
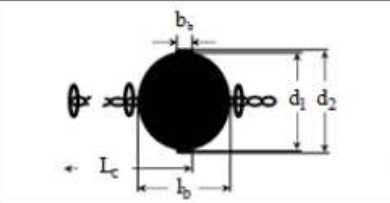
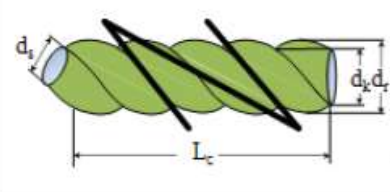

Figure 34. Test tank/basin.

The following 5 models in scale 1:5 were tested: Short and long-linked chain, Rockhopper, Bobbins and a 4 stranded rope. An overview of the models with their main particulars is given in Table 5 .

Table 5. Model data.

	Chain	Dimensions (mm)				Number of links	Length L_m / L_c (mm)	Weight in air (N)
		d	t	b ₁	b ₂			
		Short-linked	6	18.6	9.5	19.7	22	421/400
Long-linked	6	41.7	13.5	24	10	429/408	2.65	
	Rock-hopper	Dimensions (mm)				Number of discs	Length L_m / L_c (mm)	Weight in air (N)
		Spacer		Disc				
		ls	ds	ld	dd	8	390/318	4.4
	Bobbins	Dimensions (mm)				Number of bobbins	Length L_m / L_c (mm)	Weight in air (N)
		Width		Diameter				
		b ₁	b ₂	d ₁	d ₂	5	390/189	3.35
	Rope	Dimensions (mm)				Number of Strands	Length L_m / L_c (mm)	Weight in air (N)
		Rope		Strand				
		dr	dk	ds		4	430/410	1.5
	Z-twisted	28	24	11				

The models were mounted to the carriage as shown in Figure 35. To measure the forces, a 3-component force transducer was positioned between a T-beam holding the model and a vertical cylinder fixed to the carriage. The cylinder could be rotated and adjusted vertically, and thus provide a precise control of angle of attack and vertical position of the model. The 3-component force transducer was constructed in-house from three one-axis transducers (HBM DF2S), placed in an orthogonal position as shown in Figure 35.

For each combination of speed, penetration and angle of attack, two runs were made in order to check the reproducibility.

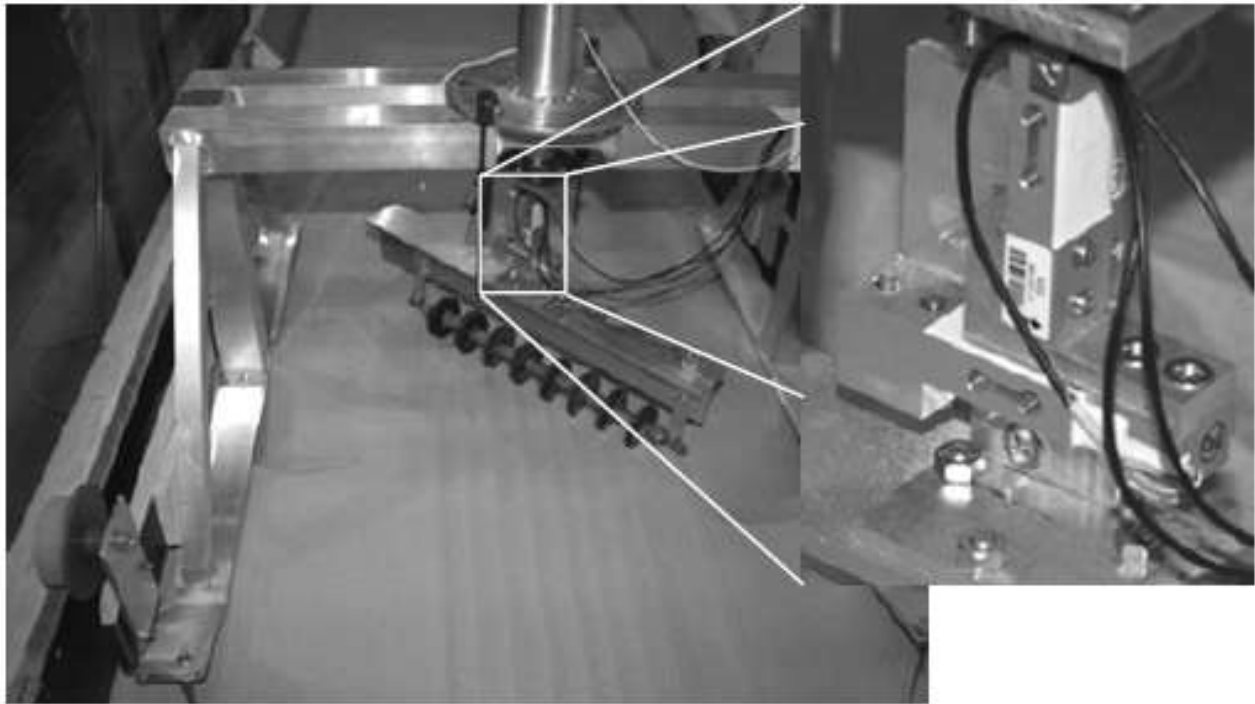

Figure 35. Carriage with model and force transducer.

The measured forces was transformed from the local axis system (f_x , f_y , f_z) to a global system (F_x , F_y , F_z) as shown in Figure 36. Definitions of axis and angle of attack (AoA).. The contact forces were then established by subtracting the hydrodynamic forces from the total forces. The contact force along the global X-axis (opposite speed) is termed the “(Seabed) Friction force”, while the force along the global Y-axis is termed the “Transverse force”. Dividing these forces by the accompanying vertical force gives two normalised forces (F_x/f_z & F_y/f_z) that can be interpreted as the longitudinal and the transverse coefficient of friction.

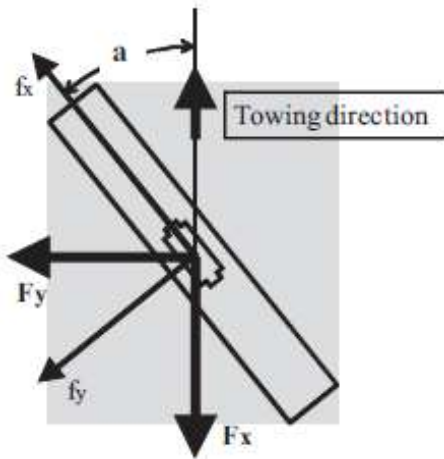

Figure 36. Definitions of axis and angle of attack (AoA).

Results

The longitudinal and transverse coefficients of friction for the 5 models are presented in Table 6 and Table 7. A graphical presentation is given in Figure 37 and Figure 38. The results relate to a water depth of 65 mm, a towing speed of 0.19 m/s and a nominal penetration depth of 2 mm into the seabed/sand. Additional results for a penetration depth of 4 mm is included in Table 6. The coefficients are presented as functions of angle of attack.

Table 6. Experimental results for short- and long-linked chain.

AoA (degr.)	Short-linked chain						Long-linked chain					
	Penetration = 2 mm			Penetration = 4 mm			Penetration = 2 mm			Penetration = 4 mm		
	f_z (N)	F_x/F_z (-)	F_y/F_z (-)	f_z (N)	F_x/F_z (-)	F_y/F_z (-)	f_z (N)	F_x/F_z (-)	F_y/F_z (-)	f_z (N)	F_x/F_z (-)	F_y/F_z (-)
0	1.23	1.37	-0.19	1.54	1.51	-0.23	1.46	0.89	0.07	3.39	1.16	0.00
0	0.83	1.24	-0.10	1.83	1.57	-0.21	1.53	0.87	0.05	2.73	1.18	-0.18
15	2.10	1.41	0.36	2.83	1.69	0.46	2.32	1.02	0.41	4.91	1.26	0.22
15	1.60	1.67	0.32	2.31	1.88	0.53	1.26	0.98	0.50	2.40	1.33	0.21
30	2.19	1.36	0.20	3.03	1.77	0.38	2.42	1.28	0.48	5.35	1.38	0.31
30	2.31	1.38	0.25	3.84	1.75	0.46	1.37	1.44	0.40	4.03	1.36	0.30
45	2.14	1.29	0.14	4.00	1.57	0.30	2.59	1.35	0.27	6.30	1.41	0.27
45	2.36	1.29	0.18	4.30	1.92	0.30	1.25	1.27	0.49	3.00	1.55	0.23
60	2.88	1.27	0.12	6.66	1.57	0.15	2.08	1.36	0.25	6.32	1.46	0.19
60	2.05	1.51	0.05	4.40	1.73	0.16	1.19	1.38	0.36	3.47	1.50	0.21
75	3.09	1.27	0.06				1.64	1.41	0.16	5.28	1.49	0.10
75	3.07	1.25	0.06				1.20	1.57	0.19	3.42	1.56	0.10
90	3.77	1.29	0.05	8.94	1.46	0.06	2.03	1.26	0.06	3.54	1.61	-0.04
90	3.05	1.28	0.01	5.36	1.79	0.05	1.26	1.40	-0.04	3.32	1.69	0.02

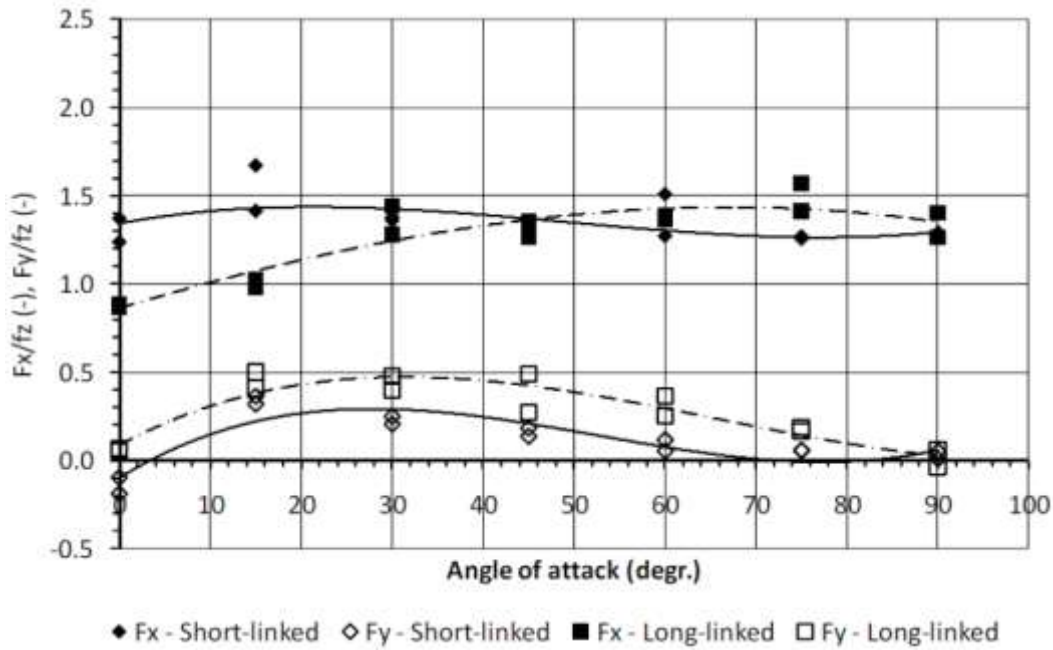

Figure 37. Coefficients of friction for short- and long-linked chain.

Table 7. Experimental results for rockhopper, bobbins and rope.

AoA (degr.)	Rockhopper			Bobbins - free/rolling			Bobbins - fixed			Rope		
	fz (N)	Fx/Fz (-)	Fy/Fz (-)	fz (N)	Fx/Fz (-)	Fy/Fz (-)	fz (N)	Fx/Fz (-)	Fy/Fz (-)	fz (N)	Fx/Fz (-)	Fy/Fz (-)
0				1.94	1.09	-0.11				2.89	1.24	0.05
0				2.72	1.07	-0.01				3.58	1.42	0.00
15	5.18	1.57	0.05	2.51	1.09	0.00	2.84	1.03	-0.01	5.32	1.32	0.06
15	4.03	1.69	0.03	2.10	1.18	-0.04	2.40	1.08	-0.03	2.17	1.26	0.11
30	8.91	1.52	-0.13	2.26	1.02	-0.14	2.97	0.97	-0.01	5.44	1.22	0.02
30	6.22	1.57	-0.13	2.07	1.09	-0.16	2.31	1.02	-0.01	1.64	1.02	0.05
45	8.91	1.36	-0.18	2.85	0.84	-0.31	2.94	0.96	-0.08	3.82	1.02	0.00
45	6.67	1.39	-0.20	2.45	0.85	-0.31	2.33	0.96	-0.08	1.65	0.96	0.12
60	8.22	1.17	-0.12	2.60	0.65	-0.43	2.79	0.88	-0.04	3.44	0.92	0.05
60	5.46	1.24	-0.20	2.30	0.66	-0.43	2.08	0.99	0.01	2.00	0.92	0.02
75	8.11	1.01	-0.10	2.31	0.51	-0.39	3.18	0.76	-0.01	3.32	0.92	0.00
75	5.57	1.04	-0.10	2.04	0.55	-0.49	2.36	0.74	-0.01	2.00	0.88	0.00
90	6.70	0.98	-0.02	2.00	0.35	-0.08	2.28	0.70	0.01	2.20	0.95	0.01
90	6.00	1.01	0.00	2.13	0.32	-0.02	2.53	0.66	0.00	1.12	0.82	0.04

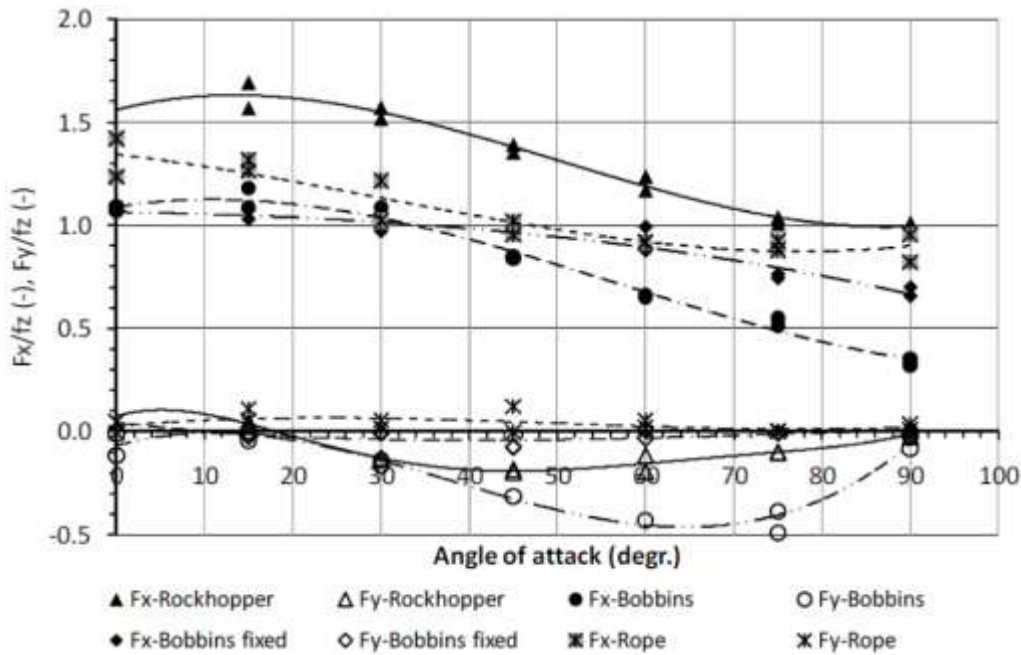

Figure 38. Coefficients of friction for rockhopper, bobbins and rope.

For the short-linked chain the results show a friction coefficient that is almost independent of the angle of attack. This can be explained by the small contact/frontal area of each link, which can be perceived as “point” contacts, with very little sand transported in front of each link. Both type of chain will, however produce a positive transverse, or “spreading”, force which for the short-linked chain is a bit contradictory regarding the explanation above. For 0 and 15 degrees AoA, the bobbins were sliding, not rolling as for the larger AoA. As soon as the bobbins started to roll the drag was gradually reduced to its lowest level at 90 degrees AoA. A rolling banded bobbin will also produce a negative transverse force as a result of the band penetrating the soil. With the bobbins restrained from rolling (fixed), the friction coefficient is only slightly decreasing with increasing AoA. Fixed bobbins produce no significant transverse force. The rockhopper shows the same pattern as the bobbins: The friction coefficient decreases as the AoA increases and contact area is reduced. The rockhopper produces a small negative transverse force, presumably from a plowing force generated by the discs.

About ropes, penetration of 2 mm only the top of strand is in contact with seabed. At small AoA a larger part of the seabed will be in contact with the strands, and thus give a higher drag that at large AoA.

Hydropêche: experimental and numerical developments for fishing devices optimisation

Gregory GERMAIN¹, Elkhadim BOUHOUBEINY^{1,2}, Anjara GENCE³, Ilye MNASSRI⁴, Ramez KHALED^{5, 6}, Philippe DRUAULT², Benoit VINCENT⁴, Daniel PRIOUR⁵, Jean-Yves BILLARD⁶

¹ Hydrodynamic Service, IFREMER, 150 Quai Gambetta, 62321 Boulogne-sur- Mer, France

² University Pierre et Marie Curie-Paris 6, IJLRA, Case 162, 4 Place Jussieu, 75252 Paris cedex 5, France

³ IRMAR, Campus Baulieu, Univ. Rennes 1, 35000 Rennes, France

⁴ Marine Technology Laboratory IFREMER, 56 100 LORIENT, France

⁵ Marine Technology Laboratory, IFREMER, BP 70, 29280 Plouzane, France

⁶ IRENAV, Ecole Navale, 29240 Brest, France

Summary

It is assumed that most of fuel consumed during a fishing trip using “classical” bottom or pelagic trawls is used to tow the fishing gear, the trawls being responsible for the largest part of the fuel consumption during fishing operations. Recently, new twine materials have been tested in some parts of the trawls with the aim of reducing twine diameter and therefore the drag. Ward & al. [14] studied trawls involving novel materials, which led to a drag cut down of 6 % and a mouth opening increased by 10 %. Parente et al. have improved bottom trawls by using larger meshes and by changing the panel cuttings, which generated fuel reductions of up to 18 % and a potential increase of the net cash flow up to 27 %. The project presented here and named HydroPêche aims to develop tools for automatic optimization of trawls in order to minimize the drag of the gear. For that purpose, different aspects are addressed both experimentally and numerically. They aim in particular:

- to extend the basis of experimental data on flow characteristics governing the hydrodynamic behavior of different porous structures (sheets of net, trawls)
- to develop numerical tools to simulate more realistic flow around porous structures
- to integrate the structure behavior in the previous codes in order to take into account fluid/structure interactions
- to develop automatic optimization tools to design efficient trawls in terms of energy consumption (value of the drag of the gear by respecting a number of both economic and environmental constraints) and to adapt the numerical code for routine used by an optimizer.

Optimization of fishing devices

Based on the FEM numerical model, the constrained optimization tool developed starts from a reference geometry. A successive search per parameter method is then applied to find the most efficient trawl in terms of energy consumption. This automatic optimization tool can be used for both pelagic and bottom trawls but a specific optimization target should be applied in each case,

being careful not to decrease the quantity of fish caught by year. The fuel consumed per year is directly linked to the drag by the towing distance by the swept width for bottom trawl and by the mouth surface for pelagic trawls. In order to decrease the fuel per catch, the objective functions used are then: the drag over swept width ratio for a bottom trawl and the drag over the mouth surface for a pelagic trawl. The drag is the total drag on the trawl (Cables, netting, floats). The swept width is the mean value of the top horizontal opening and bottom horizontal opening. The mouth surface is the surface of the trawl projected onto the plane normal to the towing speed. In previous works, the cables, floats and dead weights remain constant during the optimization process. Results obtained on both bottom and pelagic trawls were relatively good (improvement of respectively 17 % and 39 % on the fuel consumption) even if it leads mostly to an increase of mouth surface rather than a decrease of the drag.

Conclusions

The tools presented here should provide a gain of minimum 10 % on the fuel consumed by current fishing devices while maintaining a comparable fishing efficiency. The developments made will also be extended to study different types of porous structures used for fishing and aquaculture devices (nets, cages, seines) and to understand the development of selectivity devices better.

New hybrid diesel electric propulsion system for trawlers

EMILIO NOTTI¹, GAETANO MESSINA¹, ANTONELLO SALA¹, CLAUDIO ROSSI²

¹ Consiglio Nazionale delle Ricerche, Istituto di Scienze Marine, (CNRISMAR), Largo Fiera della Pesca, Ancona, 60125, Italy.

² Alma Mater Studiorum Università di Bologna – Dipartimento di Ingegneria Elettrica, Via Risorgimento, 2 – 40136, Italy.

Introduction

Due to the poor state of the fishery resources, trawlers are not profitable as they use to be. One way of improving their profitability is to reduce operational costs, especially by reducing fuel consumption. In the propulsion system herein proposed, the overall power required by the vessel is subdivided in multiple power units, each one obtained by coupling a diesel engine with a permanent magnet brushless electric generator, while the propeller is coupled with an electric motor. Through an electronic management system, it is possible to maintain one or more power units at different operating points to guarantee the minimum overall fuel consumption. In this study two power units have been considered. Many load tests have been done on a marine diesel engine, to evaluate its fuel consumption, torque and power delivered against the revolution speed. An algorithm to control the power units have been obtained from experimental data. The carried tests demonstrated the so conceived propulsion system as really reliable. A fuel saving of

up to 15% was achieved with a power units equipped with a 257 kW @ 3800 rpm diesel engine. The proposed propulsion system could be useful both in new vessel and for a re-dumping of existing vessels. Further advantages are related to the possibility to avoid propeller shaft and reduction gear, then reducing weights, noise and pollution.

Hybrid propulsion system.

the proposed hybrid Diesel- Electric propulsion system Figure 39 consists of one or more power units (1 and 2) constituted by a diesel engine connected to a brushless permanent magnet synchronous generator (3). Each power unit is connected to an inverter which converts line voltage AC into DC. The DC bus of the power units are the inputs of the multilevel converter (4). A power management system, trough the converter, is able to manage in a flexible way the power units and to stabilize each of them at a optimal operation point. The propeller is driven through a gearbox, or by direct drive, from a brushless electric motor (5) sized for maximum power from the power units installed.

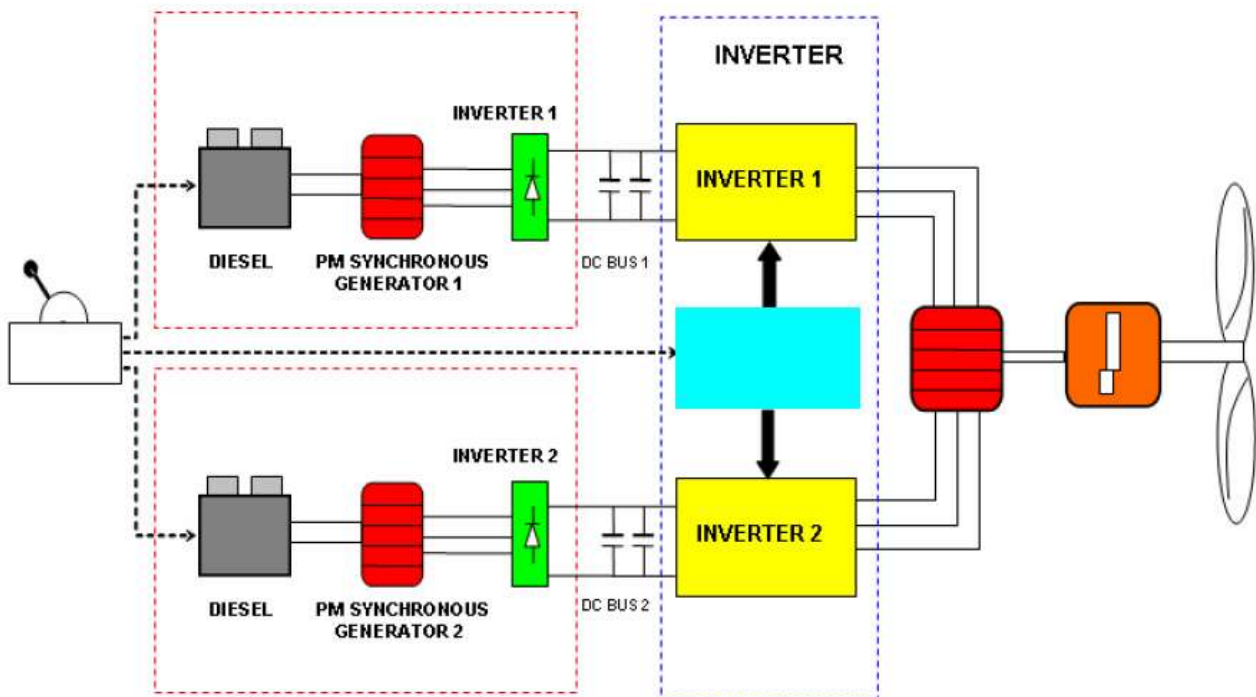

Figure 39. Hybrid propulsion system layout.

Working system

The electronic power management system can administrate the power units on the basis of the characteristics of the power unit's diesel engines. So that, diesel engines must be preliminary tested. Torque, delivered power and specific fuel consumption are recorded at different engine loads against revolution speed. The experimental data allow to create a map of the specific

consumption against the delivered power, the torque and the revolution speed. This map of specific fuel consumption, allows to derive the performance of the diesel engine depending on the output power. Test results of a diesel engine of 257 kW @ 3800 rpm are shown in Figure 40. Each point on the map in Figure 40 corresponds to a specific consumption value, referring to a pair of values of torque and revolution speed. The area in the center of the map represents the lowest specific consumption with 210 g/kWh. The lower area of the graph and areas above the central zone are of low efficiency. Iso-power black curves represent fraction of the nominal power.

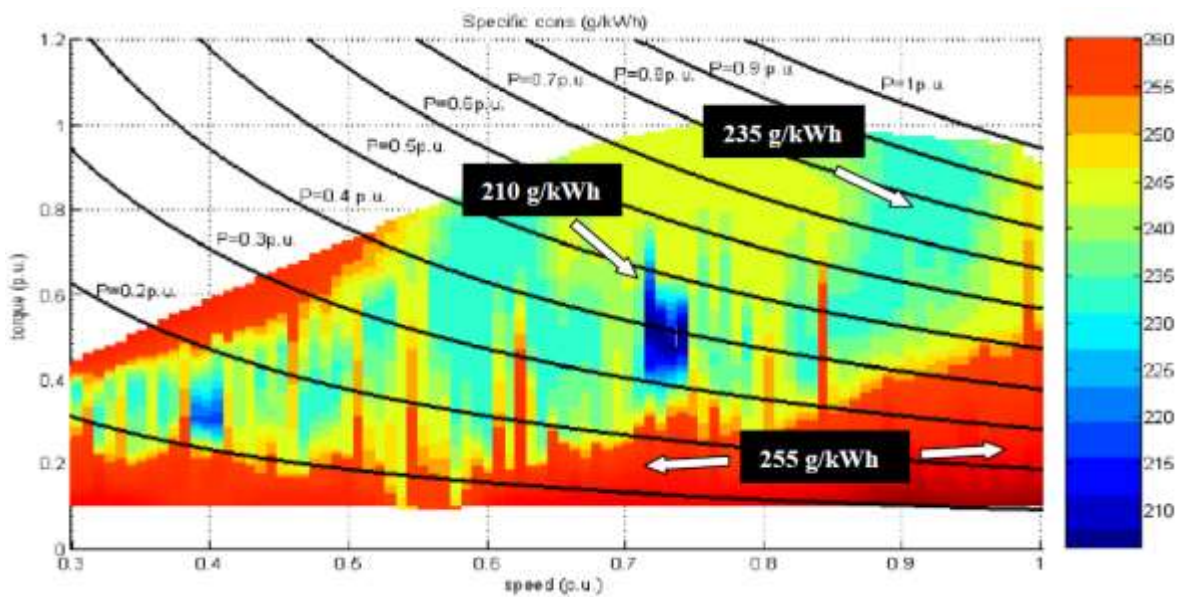

Figure 40. Fuel consumption map of the 257 kW engine tested

By the processed data, the relation between specific fuel consumption and power delivered has been obtained Figure 41, where it is showed the minimum specific fuel consumption of the diesel engine for any output power in optimal operating conditions. The power output is expressed in terms of fraction of the nominal power. It can be noted that the best operating condition for the engine tested is around 0.4 p.u., corresponding to an output of 100 kW.

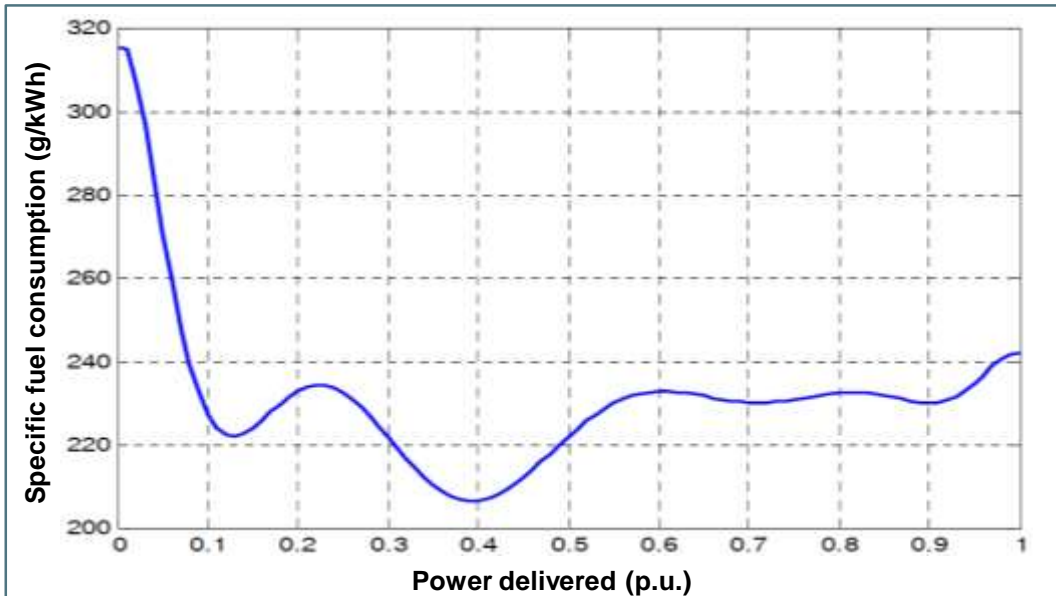

Figure 41. Fuel consumption against power developed expressed as a fraction of the nominal power.

Power management system controls the power units in order to determine how much power each of them must provide. For each power request, Figure 41 represents the lowest specific fuel consumption obtainable. Known the power request, the subdivision of this power among power units is operated by a variable parameter k , called "Power Sharing coefficient".

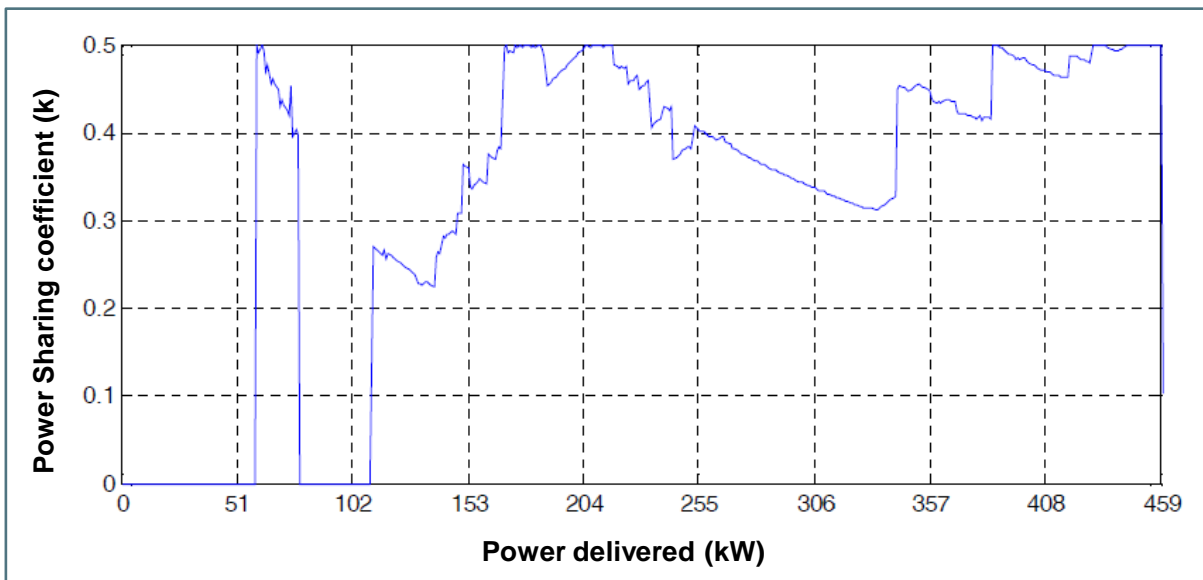

Figure 42. Power Sharing coefficient trend.

Through a series of algorithms relating Power Sharing coefficient k to the required power, Power sharing coefficient trend is obtained against power required. k values range between 0 and 0.5. When $k = 0$ only one power unit is running; when $k = 0.5$, both units deliver the same power. In Figure 42 there are three areas in which k is kept equal to around 0.5:

- The first zone, about 60 kW, is only transitional.
- The second zone, between 160 and 210 kW, the diesel engine has low consumption if maintained at about 100 kW.
- The third area is related to the maximum power request.

An example will clarify the operating principle of the system set out above. A system composed of two power units, each one equipped with a 257 kW diesel engine, must deliver 200 kW. Each power unit could supply the requested power with a specific fuel consumption of 230 g/kWh. Each diesel engine, at the minimum specific fuel consumption operating point, provides 100 kW with a specific fuel consumption of 210 g/kWh. So both engines will be used, each delivering 100 kW. As a result, the total power has been delivered, under optimal conditions with a 10% of fuel saved.

Results and discussion

A fuel saving up to 10% was experimentally achieved. Supposing a daily consumption of 1000 l/day (typical fuel consumption of a 35 m LOA pair trawl fishing vessel), four days per week and four week per month, theoretically the fuel consumption can be reduced of about 1600 l/month, corresponding to 1120 €/month, at a rate of 0,70 €/l. The yearly economic saving will reach about 11000 €/year. Due to the continuous rising up of the fuel price, the more the fuel price increase the more the fuel saving obtained will be useful. A propulsion system consisting of few power units suggests further advantages. First of all it is possible to include in the total amount of power installed the auxiliary power generator, usually of low efficiency. Shaft and reduction gear are lacking then reducing weights and maintenance costs. Furthermore, even if a power unit would be damaged, others will warrant a minimum thrust. Noise, pollution and vibration can be reduced. Weights onboard could also organized in a better way, improving sea keeping and stability.

1.7 French Fisheries

Project synthesis

Optitrim

Quite often fish boats appears to have positive trim (the rear is lower than the front). This parameter has an influence on the performance of the boat and this influence is not well understood. This projects has planned to conduct trials at sea and in basin in order to improve knowledge and to bring remedies. A guide for professionals will be broadcasted which could allow skippers to assess its own case and offer solutions to improve the trim (loads distribution onboard, new appendices...). This project is brought by Cofrepêche.

<http://www.cofrepeche.fr/index.php>

Cochise

Optimization of trawlers is quite seldom. Usualy shipyards propose fishing boats issued of previous realisations without a phase of definition upstream. The objective of the project is to rethink the design of the boat using up-to-date technologies in order to improve energy consumption as well as confort and safety. The expected economy is 15% in operating costs for vessels from 16 to 24 meters. The project will produce one or two designs of vessel. This project is led by Bureau Mauric.

<http://www.mauric.com>

Effichalut

The objective of this project is to improve trawl design in order to decrease the fuel consumption. The project is based on bringing to a professional (partner of the project) further information issued from measurement at sea and numerical simulation. The measurement at sea concern tension in cables and openings of the trawl. The numerical simulation involved the trawl in work. With the help of this information the professional has modified his trawl design. The economy in fuel consumption measured on few month shows an economy of 17% without loss of catch. This project is led by CME.

<http://www.cmeop.com>

Optipropulseur

The objective of this project is to improve the propeller efficiency. Several propulsion equipment developed for military applications are used to guide the flow of water upstream of the bow and reduce energy consumption. Fuel savings issued of the application of these techniques is expected reach 20%. This project requires tank tests to examine all physical phenomena and to optimize the characteristics of the propeller. At the end of the project, a specification containing recommendations for maximizing the thrusters will be broadcast. This project is led by Shipstudio.

<http://www.shipstudio.com/>

Ecomer

The fuel flowmeter is a means to control the fuel consumption in real time. The project aims to develop a flowmeter which could record and differentiate the consumption posts. By this accurate information the skipper is able to adjust and to optimise the fuel consumption. The tool is based on sensors for the measurement of the energy and a software to facilitate the optimisation. The project is held by shipyard Glehen.

<http://www.chantier-glehen.com>

Survey

This survey has been carried out on Brittany fisheries during 2007. It aims to establish an inventory of the practices of fishermen in terms of fuel economy. It promotes an exchange of practices between professionals and get ideas to improve their fuel consumption. The survey has shown that 2/3 of ships surveyed have already been modified in order to achieve fuel savings. 3/4 of these changes relate to the process of fishing trawlers. For the rest, these changes are related to:

- The hull (bulbous bow) and maintenance,
- To all the ship's propulsion system (engines, propellers, nozzles etc..)
- The provision of electricity,
- The mode of operation (approximation of the places of business etc..),
- Behavior (buying an econometrician etc.).

The project has been held by Comité Régional des Pêches Maritimes et des Elevages Marins, Bretagne.

<http://www.bretagne-peches.org>

Additive

The project has been carried out in 2006. The objective was to test additives to diesel and engine accessories (catalytic combustion) to limit the consumption of fuel on marine engines. Under the conditions of the test bench, namely:

- New engine, clean, upgraded before each new test;
- Test performed for 150 hours during which the diesel flowing in closed circuit with an electric pump;
- And then test for 50 hours in the circuit of the motor fuel, operating under conditions of use
- similar to those of a fishing trawler;

The test results of the additive and combustion catalysts remain at the margin of imprecision of measuring devices, around 2%, making the test non-significant in terms of fuel economy and

emissions of pollutant. The project has been held by Comité Régional des Pêches Maritimes et des Elevages Marins, Bretagne

<http://www.bretagne-peches.org>

Optipeche

The project aims to create new tools to reduce operating costs, the impact of gear on the bottom, but also to improve the selectivity of catches and increase the safety on board. Few tasks are planned:

- A multibeam echosounder "low cost" is developed in order to see the positioning of the trawl. The technology is based on two modules i) detect fish, ii) identify and classify automatically the seabed. A software displays real-time data on the bathymetry and the type of seabed, providing better security to trawling while greatly reducing operating costs of the ship.
- Trawl sensors are developed in order to measure the opening of the net, cables tension, door spread. These improvements lead i) to improve the selectivity and the quality of the catch, ii) to reduce the impact on the seabed and iii) to save energy.
- Doors more environmentally friendly are developed. Depending on their position, these small doors can provide up to 20% fuel economy.

The project is held by IXTRAWL

<http://www.ixtrawl.com>

Grand Largue

The project proposes a use of wind force, taking into account the constraints of work. This is not to dispense diesel fuel, but to combine propulsion sail with propulsion provided by the engine. Under control of a software, wind energy is coupled to the diesel fuel to get the best performance. Depending on wind and current, an optimal routing will be proposed to the skipper. Experienced at first on a 16 meter trawler, the test shall be performed in real operating conditions of a seiner and a dredger. The project is held by Avel Vor:

http://www.avel-vor.fr/Projet_Grand_Largue

Itsasoa

The objective of this project is to test the feasibility of a production chain of vegetable oil produced near the port where it will be used by vessels fishing. It is first necessary to validate the operation of fishing vessels and engines. So they will work for a full season with the sunflower oil from nearby farms. In parallel, a supply chain to meet the needs of two experimental vessels will be implemented. Then it is to organize the production of vegetable oil, to check quality and make it available ships. Currently, a liter of vegetable oil fuel is sold around € 0.9, but local production could reduce transportation costs. Thus, such organisation would allow fishermen to provide

vegetable oil fuel whose price would evolve more slowly than that of diesel fuel. The value of products with reduced environmental impact (reduction of CO2 emissions, local production) is also considered. The project is held by the Institut Français des Huiles Végétales Pures <http://ifhvp.fr/>

Hydropeche

This project is a research one. The hydrodynamic behavior of porous structures used for fishing (trawls, traps, cages, seines) is still poorly understood. Trawls are responsible for the largest part of fuel consumption in French fishing. This project aims to develop a design tool to minimize the drag of the trawl. For this, various aspects need to be addressed both experimentally and numerically. They aim in particular:

- To extend the experimental database on the characteristics of the flow governing the hydrodynamic behavior of different netting structures;
- To develop numerical tools to simulate a more realistic flows around porous structures;
- To integrate the party structure in the previous codes for the consideration of the interaction phenomena fluid / structure;
- To develop tools for automatic optimization for designing efficient trawls in terms of energy consumption.

The tool thus developed is expected provide a gain of about 20% of the drag of a trawl, while maintaining an efficiency comparable fishing. The developments made will also be extended to study different types of porous structures used for fishing and better understand the development of selectivity devices. The project is held by the IFREMER

<http://wwz.ifremer.fr/hydropeche>

NS3

The project concerns the small coastal vessels (10-14 meters) for which, improvements on the hull and propulsion are proposed. Few tasks are planned i) to validate the performance of new forms of hull, ii) to test adapted propellers and iii) to develop a gantry facilitating versatility between fishing techniques. The ultimate goal is to make ships more efficient in terms of energy, but also to give them the opportunity to practice several métiers in order to adapt to market changes. The project is held by K-epsilon.

<http://www.k-epsilon.com/index.php>

Bulb

Many skippers currently equip their ships with a bulb to improve the energy performance. These appendices are sometimes constructed empirically and may have a negative effect on the performance of the ship. The project aiming to develop a tool for simulation and optimization of the bulb in order to:

- Validate the potential gain before performing the modification of the ship at significant cost;
- Optimize the bulb according to the mode of operation of the ship.

The installation of a bulb will be studied precisely in order to consider its potential for gain and to optimize the shapes. The simulation tool will be used to equip a Mediterranean trawler and validate the gains envisaged. A design guide will be distributed to naval architects. The project is held by Jean & Frasca Design:

<http://www.jean-et-frasca.com/index.htm>

RP3E

The project focuses on one area: the French Mediterranean. Several points that make the profitability of a fishing business will be studied: fuel consumption, but also the marketing of its products. Experiments will be conducted from three ships:

- On a pelagic trawler, the experiments will focus on trawl in Dyneema, warps of synthetic fiber and new lightweight doors. The experiment is to measure, in situ, consumption gains realized respectively by improving the trawl, the warps and the doors. The experiment should also allow to check the transferability of such improvements on the trawl fleet.
- On another trawler, nephrops traps will be tested to determine the best use of such equipment by targeting a scarce natural resource, but not threatened : nephrops.
- On a tuna seiner, jig fishing for squid will be tested. Squid is a specie slightly exploited and has a relatively short life cycle, which make it less vulnerable to exploitation.

The originality of the project is to evaluate the threshold energy savings compared to the economic situation of the market for seafood, and the key factor is the use of three ships within the same sales area: the French Mediterranean. The project is held Cepralmar.

<http://www.cepralmar.org>

ITIS

The project is partly dedicated to energy savings. It will develop i) a new tool for observation and characterization of fisheries resources and ii) fishing gears more respectful of the quality of the catch. The project has two components:

- ACSYS as "ACoustic SYStem", aims to use acoustic technology for detection but also for the identification and characterization of the biological resource to allow a better selectivity in catches,
- SQUAL, like "Selectivity, catch QualLity and Alternative gears" aims to test innovative fishing gears, including trawls exercising less mechanical stress on the catch for a higher quality and better utilization of fisheries products. The project will also test fish traps and nephrops pots.

This work will be done in conjunction with the fishermen of the Gulf of Biscay. The project is held by iXTrawl.

<http://www.ixtrawl.com>

Shyper

Hydrogen propulsion will take many years before being developed, however, it is interesting to study today ships which can use this method of propulsion. Indeed, the use of hydrogen poses technical, economic or security that can now be studied. The objective of the project is to determine the characteristics of a ship powered by hydrogen and then to consider the fleets are likely to use this technology. In this project it is expected to produce hydrogen from renewable energy (wind, tidal, wave, solar ...). The project is held by Mission Hydrogène

<http://www.missionh2.org>

Halieukyte

The project proposes to test the feasibility of propulsion by kite for fishing vessels. A German company already offers a system for cargo, but the constraints of a fishing vessel are more difficult (change of direction, activity, speed, etc.). Wind distribution will be studied as well as profiles of ship fleets in order to determine the installation of kite would be interesting. In case of significant gains, a test shall be performed to validate the use of a kite aboard a ship. Deployment issues of the kite and the security will be studied because they may be major barriers to the use of this type of propulsion on board fishing vessels. The project is held by K-Epsilon

<http://www.k-epsilon.com/index.php>

Optiperf

Currently, the optimization of hydrodynamic performance of hulls of fishing vessels is provided by tank tests. They are expensive in investment and personnel. The project proposes to develop a numerical tool that will optimize the hull without going through these tests in order to reduce design costs. At the end of the study, an optimized hull repository will be sent to naval architects. By the way naval architects could compare their projects to the repository. The project is held by Hydrocean

<http://www.hydrocean.fr>

Monocat

The project focuses on the development of a new hull form that combines the benefits of monohulls (waves passage), and multihull (comfort, space available). The studies are conducted for a tuna longliner for the Pacific. It will be transposed to usual vessels (potters, gillnetters and eventually trawlers 10-14 m). This project will provide a solution for the fleet using passive gear. The project is held by Groupe Fauroux

<http://www.fauroux.com/architecturenavale/monocat/monocat.html>

Visit of SHIPSTUDIO

SHIPSTUDIO is a naval architect company, with 9 people and a annual turnover around 900K€. The director is Laurent MERMIER. There are three offices:

- 1.Lorient : 58 avenue de la Perrière56100 Lorient - Francetel +33 2 97 50 38 05
- 2.Nantes : 6 rue Baboneau44100 Nantes - Francetel +33 2 40 46 71 01
- 3.Rouen : Rue Marcel Paul76150 Maromme - Francetel +33 2 32 08 49 44

Web site is <http://www.shipstudio.com/infos.htm>

Email address is contact@shipstudio.com

The main activities of Shipstudio are:

- naval architecture,
- hydrodynamics,
- detailed design
- implementation and specific studies
- assistance and follow-up work for all types of ships and floating structures (buoy).

Shipstudio is the coordinator of the project OPTIPROPULSEUR. The partners of this project are:

- MASSON MARINE , 5 rue Henri-Cavailler ,89100 Saint Denis les Sens
- MASSON MARINE ENGINEERING , 5 rue Henri-Cavailler ,89100 Saint Denis les Sens
- AGLIA , Quai aux vivres ,17314 Rochefort Cedex
- CRPEM Bretagne , 1 square René Cassin ,35700 Rennes
- MPI , 13, rue Bernard Roy ,44100 Nantes
- GTN , 2 rue du parc aux oiseaux ,95270 Asnières sur Oise
- DGA , Bassin d'Essais des Carènes , Chaussée du Vexin ,27105 Val de Reuil

The objective of the project is the improvement of the propulsive efficiency of fishing vessels.

Issues and objectives:

The project will provide devices to improve the propulsive efficiency of fishing vessels. The project aims new boats but also existing vessels. The energy consumption of fishing vessels depends mainly on four factors: 1) The type of fishing 2) The profile of vessel use 3) Performance of fishing gear 4) The energy performance of the ship. The latter is related to the characteristics of the hull and propulsion system. The project focuses on the latter factor, in which significant gains in energy performance are possible.

Origin of the project:

The naval ship engineering Shipstudio in partnership with the Aglia, with the support of Brittany and Pays de la Loire regions has been engaged for three years a series of works on reducing dependence of vessels on diesel. Simple solutions to be implemented on existing vessels are preferred. Encouraging initial results were obtained with the addition of a pre-rotation stator for a propeller in nozzle. This first exploratory stage was an opportunity to convene a technical partnership wider, causing the project and gathered around the project OPTIPROPULSEUR.



Figure 43. Vessel used for sea tests

Programmed tasks:

1. Field survey to identify the patterns of use of fishing vessels,
2. Definition of technical solutions: a) Improved propeller efficiency, b) Improving the design of nozzle, c) Using the pre rotation (recovery of the kinetic energy of rotation), d) Optimization of adaptation propeller with the hull, e) Using innovative propulsion (type propeller pump)
3. Validation of the solutions in a test tank,
4. Studies and industrial achievements,
5. Tests on real fishing boats.

Target applications:

All fishing vessels should benefit from optimized propeller that will be developed under this project. Existing ships are particularly concerned. The amendments to these vessels outside the propeller must remain minimal. Particular attention will be paid to the economic evaluation of proposed solutions. These solutions will have a significant economic gain and a fast return on investment.

Tools and method:

Three mains tools are used along the project:

- Numerical simulation using CFD software aims to study the potential of modifications on the propeller.
- Tests in basin are used to verify few modifications validated by the numerical simulations;
- Tests at sea is to verify the final modifications validated by the basin tests.

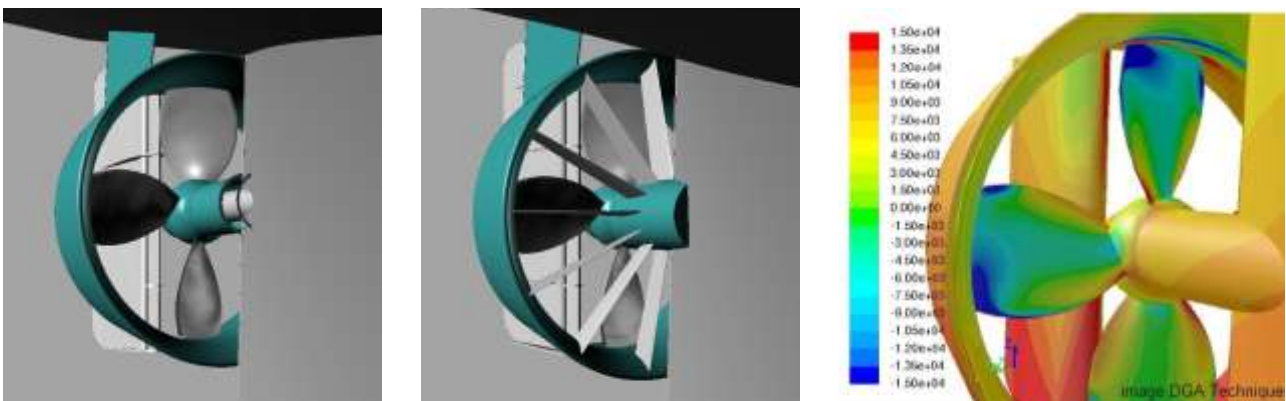

Figure 44. Numerical simulation using CFD software of an original propeller

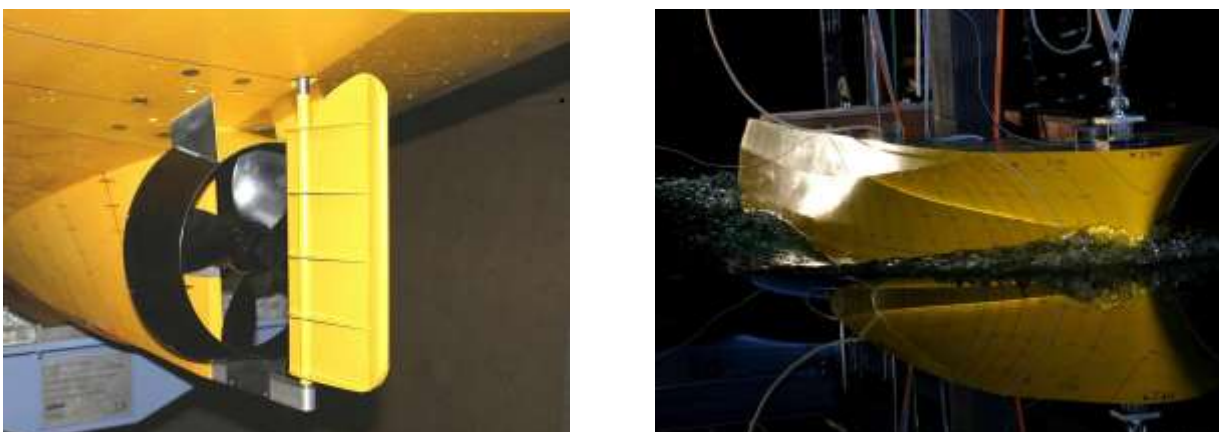

Figure 45. Basin test of the vessel

Expected improvements:

Depending on the modification brought to the propeller system the expected improvement of the efficient could be more or less large:

- The rudder is behind the propeller and the water speed around the rudder is much more larger than around the hull. Due to this increase of water flow, the rudder has to be well designed. Generally speaking they are just a metal plate welded to the shaft. The numerical simulations show that a potential of improvement of 5% on the efficiency is expected when the rudder is ducted.
- The rotation of the propeller leads to the rotation of the water vein. In order to reduce the loss of kinetic energy in the rotation of water, a pump stator is displayed before the propeller. The expected economy is around 5%. The cost of such equipment on a boat of 24m long is around 15K€.
- The distance between the extremity of the propeller blades and the nozzle influence the efficiency of the propeller: smaller the distance larger the efficiency. The project expects to find simple solutions to reduce this distance. The expected economy is around 5%.
- The blades are generally derived from previous designs. A re-design of the blade associated with a stator is expected to improve efficiency by 10 to 12%.
- A whole propeller pump (stator, rudder, blades, nozzle) is expected improve the efficiency of the propulsion by 20%. The cost of such equipment on a boat of 24m long is around 45K€.

1.8 Scottish Fisheries

Scotnet International – Gears of reduced drag and Selective fishing gears. Fraserburgh, Scotland.

Scotnet International is based in Fraserburgh, Scotland and employs one person. About 40% of its nets are for the Nephrops sector, 30% for the whitefish sector and about 30% for the squid and cuttlefish fisheries. While it is a small operation it has been trying to introducing fuel efficiencies into the gears it designs in a number of ways. Methods employed include: increasing mesh size of panels in the top sheet; reducing twine thickness; using Dyneema rope headline (which is lighter and requires up to 30% fewer floats); using Dyneema rope in the warps ahead of the doors, which it is thought gives more spread, permitting a reduction in the size of door that needs to be used. Scotnet have also been involved with the development of more selective Nephrops and had investigated (a) placing square mesh panels in four panel sections in the extension and (b) large square mesh netting sections ahead of the taper.

Gamrie Bay Prawn Trawls – Selective fishing gears. Gardenstown, Aberdeenshire, Scotland.

Gamrie Bay Prawn Trawls is a family run business making Nephrops, squid, queenie and whitefish trawls. Recently they have developed a Nephrops trawl that has become known as the Gamrie Bay Flip/Flap Grid trawl. This gear incorporates the following features

- A vertically mounted panel of large mesh (200mm) attached from selvedge to selvedge over the top panel only, the bottom half being allowed to swing free. This panel is the Flip Flap Grid (FFG) and is positioned 3 meshes from the end of the taper.
- The bottom half of the panel is assisted in maintaining a more vertical position by 1.5m of leadrope attached around the sides and lower edge.
- In the top panel, immediately forward of the FFG is a triangular escape gap 26 meshes wide at the base and cut forward on a 'V'
- A 3 m long SMP (200mm mesh size) positioned 1.5 m forward from the end of the tapered section.
- Wings and top panel down to the end of the taper constructed from 160 mm mesh.
- Bottom panel and extension constructed from 3mm single twine of 80 mm mesh size netting.

The idea behind this design is that a proportion of smaller fish would be released through the large mesh SMP. Fish too large to get through the meshes of the SMP – in particular large cod - would be further encouraged by the FFG to leave through the escape gap positioned directly above.

Valuable fish such as monkfish (anglerfish) which may be expected to move close to the bottom panel even when stimulated by a device such as the FFG would hopefully overcome the resistance presented by the weighted section and proceed to the codend. Nephrops are expected to pass through the large meshes of the FFG.

Three sets of trials have taken place and the results show that

- fewer cod, haddock and whiting are retained in the Flip/Flap Grid trawl in comparison to the commercial gear;
- the retention of cod varies considerably from haul to haul whereas the retention rates of haddock and whiting were more consistent.

Faithlie Trawls – Gears of reduced drag and Selective fishing gears Fraserburgh, Scotland.

Faithlie Trawls is based in Fraserburgh, Scotland and employs 9 people. It makes nets for the whitefish and prawn sectors of the fishing industry with approximately 30% of orders for the former and 70% for the latter. It finds that while a lot of skippers are interested in achieving fuel efficiencies, often they are not prepared to make the initial invests that are often required. One of the main difficulties faced is that gear based fuel efficiencies are usually (if not always) associated with a reduction in drag which if to be fully taken advantage of would also require a downsizing of trawl door. Few skippers are prepared to make this additional investment and it is at this stage their interest wanes. Recently, however, Faithlie Trawls have developed a new nephrops gear, called the 'letter box' trawl which is designed to reduce the capture of juvenile whitefish. Anecdotal reports from skippers who have trialled it and preliminary results from on board observers suggest that it reduces the capture of juvenile whiting, some of the haddock and that it is not particularly effective for cod. The principles of the design are to lower the head line and reduce the cover as much as possible. This design has had the additional benefit of reducing the drag of the gear.

School of Engineering, Aberdeen University, Scotland.

The School of Engineering is a recently-established and modern School which offers Honours Degrees of MEng & BEng, and postgraduate opportunities in a wide range of topics across the spectrum of engineering activity. It has a large undergraduate population of around 600 students and approximately 75 postgraduate researchers, and is the only genuine School of General Engineering in Scotland. The School undertakes research in a broad range of fundamental and applied Engineering topics in Civil, Mechanical, and Electrical & Electronic Engineering. The fundamental nature of much of our Chemical and Petroleum research makes it applicable beyond traditional Engineering boundaries with many projects benefitting from the multi-disciplinary nature of the School. A high proportion this research is conducted in collaboration with industry and other researchers worldwide utilising links to other international and national centres of

excellence. All areas of research in the School are supported by modern laboratories with state-of-the-art equipment and fully networked computing facilities including major engineering commercial software. There is excellent technical support provided by electronic and mechanical engineering workshops. At present there are two research projects investigating the forces acting on towed demersal fishing gears. The first of these is examining the interaction between towed demersal gears and the seabed sediment, whereas the second is investigating and measuring the hydrodynamic forces acting on a towed fishing gear.

The interaction between towed demersal gears and seabed sediment.

(University supervisor: Dr Ana Ivanovic – PhD student: Moosa Esmaili)

The objectives of this study are

1. To develop a numerical model of the interaction of towed demersal gears and the seabed sediment using the ABACUS finite element (FE) package.
2. To undertake scale laboratory tests of a number of relevant gear components in a specially designed sand towing channel.
3. To carry out a parametric study (using the FE model) of the influence of different gear components and soil models on the drag force and penetration.
4. To compare the results with full scale gear component experiments that will take place on a scientific research vessel.



Figure 46. The Aberdeen University's geotechnical sand channels. The old one and the new one under construction.

The experimental tests will be carried out in the geotechnical sand channel at the University of Aberdeen. This channel has rails that support a trolley, to which the fishing gear component to be

tested is attached. The trolley allows the component to penetrate the seabed a desired depth, and to be towed along the channel at constant speed by a winch mechanism. It also includes a load cell which measures the drag force during that process. Scale models of different gear components such as ropes, rockhopper disks and bobbins will be tested. The Abaqus finite element software package will be used to numerically model the interaction between gear components and the seabed. This package has a library of different material models that are able to represent both the gear components and sediment materials. From simulations using these, it will be possible to estimate the penetration depth and the quantity of sediment displaced by different gear components towed across a particular sediment. The data produced generated from the experimental study program will be used to calibrate and validate the numerical model. Finally the scale model data from the sand channel experiments will be analysed in conjunction with data from full scale experiments to investigate the scale modelling laws of the interaction of towed demersal gears and the seabed sediment.

Hydrodynamics of fishing gear: An experimental study

(University supervisor: Professor Vladimir Nikora – PhD student: Steffen Khoo Gretland)

The objectives of this study are:

1. To develop a methodology for laboratory simulations of fishing gears accounting for both hydrodynamic and structural behaviours.
2. To conduct a series of laboratory experiments with simultaneous measurements of instantaneous spatial velocity fields (stereoscopic PIV) and drag force (load cell), at a range of scales from a netting element to the whole systems.
3. Based on #1 and #2, to identify those elements of the gears giving rise to the most drag and subsequently develop 'drag-reducing' modifications to those components (e.g., Streamlined beam shapes, Thinner diameter twines, Altered mesh shape configuration, T90, Altered ground gear, Alternative clumps, Alternative trawl designs, Otter board optimisation; Warp/bridle arrangements).
4. To develop a design strategy for fishing gears with reduced drag, from a scale of a gear component to the scale of the whole system.



Figure 47. The Aberdeen Open Channel Facility (AOCF).

The methodology will combine techniques developed in drag-reduction fluid mechanics, hydro-elasticity, and flow-structure interaction studies. The key approach is experimental, involving Aberdeen Open Channel Facility (AOCF):

<http://www.abdn.ac.uk/engineering/research/envhrg/facilities/aocf.php>

and its advanced multi-mode PIV system. The main body of experiments will be conducted in still water with towing models ('flying' PIV mode) which will be complemented with experiments in flowing water for selected scenarios. The data analyses will be focused on the identification of the key flow patterns generated by the gears at multiple scales, their interrelations with the fluctuating drag force, and the effects of gear geometry/structure and multi-scale elastic properties on the overall performance. Particular attention will be given to the interference effects between different components of gears and their influence on the total drag. The obtained findings will be combined together to produce a set of recommendations for fishing gear designs.

Sail Line Fish Ltd. Wind assisted fishing.

The Sail Line Fish Ltd was set up by Stuart Balfour in 2009 to investigate the potential of using sail power for commercial fishing and also the wider shipping industry. In May 2010 it was awarded funding to carry out a feasibility study into the potential of sail assisted fishing. During this time the Balpha Mast (International Patent Application pending) was developed. The Balpha Mast is a revolutionary mast system designed and built by Sail Line Fish Ltd. This collapsible mast system creates the means to utilize sail power onboard a commercial vessel without using extra crew or restricting its ability to operate. The sail system designed by naval architect Dick Koopmans is a free standing rig on a rotating mast. Forward on the boom there is a rolling jib. The aim of the system was to provide a simple rig that could be easily managed by one person that has high efficiency between performance and costs. To windward this is not the best acting rig, but it is easy to repair and maintain. It will also give relatively low forces on the existing boat. Between 60 degrees from the wind to downwind the rig is very efficient.

The system can be operated using hydraulics or for smaller vessels, a trailer winch within the cabin. It has been specifically designed to avoid operation on an exposed deck. Whilst not under

sail at sea the lowered mast will reduce the leeward effect on the vessel. Whilst in port the lower mast reduces the windage on the vessel, with less heeling effect. The Balpha Mast is designed to lower within the length of the vessel, avoiding damage whilst in port. Other features include ease of maintenance, alterations and repairs to the mast, lights, aerals and fittings. When conditions are suitable using wind for propulsion to and from the fishing grounds it will utilise a renewable resource that will also reduce carbon emissions in the process. The energy and physical space available will limit the fishing methods that can be employed, with long-lining lending itself best to these constraints; long-lining produces high quality fish and is amongst the most sustainable of commercial fishing methods.



Figure 48. The first public demonstration of the Balpha Mast on 12/07/11 at the Delting Boating Club, Shetland

The Sail Line Fish Project.

In order to take the two company products of sail system technology and low carbon fish to commercialization, an 18 month feasibility study 'to establish the potential of a sail assisted fishing vessel' has just being completed. From initial planning it was evident that sail systems had to be developed to create compatibility between the use of sail power and commercial fishing. The Balpha Mast was developed to ensure a fishing vessel could switch from a sail to motor power effectively without requiring extra crew onboard. From the study it was found the collapsed mast, due to its secured sea going condition increased the fishing time by allowing fishing to continue in marginal conditions. The semi-automated line fishing system used during study was found to be effective and compatible with the sail system. Fish analysis was also made by Shetland Seafood Quality Control to compare line caught fish with trawled fish of the same day market. A final report on this is being completed by SSQC. The study highlighted a distance sailed of 33% of the total distance covered. The overall reduction in fuel usage was 17.6%, this included fuel used during all fishing operations.

With this technology at such an early stage of development it is evident that sail assisted fishing could be commercially competitive and reduce carbon emissions in the process. The next stage in the development is a 3 year R & D project to 'design and build a purpose built sail assisted fishing vessel' This R & D project will (i) design and build the vessel and (ii) complete vessel and fisheries research for the remaining 18 months. Technical planning for the project has come together with the vessel being mostly designed by Dick Koopmans and built in Holland. An advanced design of the Balpha Mast will be built in Shetland for this vessel. In order to identify potential markets the market research company, Mr. G.Bournemouth has been contracted, starting 10/01/12 at the London Boat Show.

1.9 US fisheries

Introduction

According to the FAO, there are currently (2004) four million commercial fishing vessels. About 1.3 million of these are decked vessels with enclosed areas. Nearly all of these decked vessels are mechanized, and 40,000 of them are over 100 tons. At the other extreme, two-thirds (1.8 million) of the undecked boats are traditional craft of various types, powered only by sail and oars. These boats are used by artisan fishers.

Prior to the 1950s there was little standardization of fishing boats. Designs could vary between ports and boatyards. Traditionally boats were built out of wood, but wood is not often used now because it has higher maintenance costs and lower durability. Fiberglass is used increasingly in smaller fishing vessels up to 25 meters (100 tons), while steel is usually used on vessels above 25 meters.

It is estimated the industrial fishing fleet consist of 38,000 vessels (over 24 meters/100 GRT), which number only about one-percent of the total of 4.0 million fishing vessels in the world, actually represents almost three-quarters (72%) of all capital invested in the entire global marine fishing fleet. That kind of investment (229 billion dollars) requires colossal tonnage of fish to be hauled from the oceans on an around-the-clock basis in order to show any profitable return. A revealing statistic is that these 38,000 industrial fishing vessels consume over 20 million tons of fuel per year -- almost half (44%) of all the fuel consumed by all fishing vessels worldwide.

There is no question fuel consumption in fisheries can be reduced and should be a directive to do so from the fisheries regulators. There are new technologies and products available that reduce fuel consumption and lower exhaust emissions. A fuel reduction of just 10% would be millions of gallons saved putting money back into the fisherman's pocket.

Fuel Quality

Fishing vessels can be inefficient for a number of reasons. One of these reasons can be the diesel fuel itself. Diesel fuel quality is declining throughout the world, and we expect this trend to continue. The designs of diesel engines striving to increase performance have made a lot of advancements in engine fuel delivery to the combustion chamber. The diesel engines of today are much quieter, smoother, and also more powerful.

The quality of diesel fuel on the other hand has not advanced at the same rate as the improvements of engines. As soon as it is produced, diesel fuel begins to deteriorate. Less than 30 days from refining, all diesel fuel, regardless of the brand, goes through a natural process called oxidation. In fact, a recent survey suggests that 70% of diesel fuel sold at does not meet the Society of Automotive Engineers' (SAE) standard for diesel fuel lubricity. The three leading factors affecting fuel are:

- 1) Crude oil sources: In the past, crude oils were selected with the end product in mind because certain crudes produce high quality fuels and others do not. As crude oils become scarce, the ability to carefully select specific crudes is less economically feasible and compromises are made.
- 2) Refining Techniques: In order to increase the amount of a certain end product that can be refined from a barrel of crude, refineries now use a process called catalytic cracking. The process is economical and produces a high quality product for gasoline, but not for diesel fuel. Due to the cost advantages of this process and the increased demand for gasoline, "cracking" is likely to be the preferred refining method in the future, resulting in lower quality diesel. Another refining issue is the process used to reduce the sulfur content in diesel fuel. (Manufacturers are required to meet lower sulfur content limits due to environmental regulations.) The process has the side effect of reducing the lubricity of the fuel.
- 3) Blending: The third factor affecting fuel quality is blending. In cold weather conditions, for example, many refiners blend kerosene (or number 1 diesel) with number 2 diesel to lower the temperature at which the fuel starts to gel. This has the undesirable effect of reducing the energy content of the fuel, resulting in a decrease in fuel economy. It also may adversely affect the fuel's lubricating and performance properties resulting in potential wear on vital engine components. In many diesel fuel injection systems, the fuel itself is the only lubricant for the precision engineered injection pump.

Proper filtration of diesel fuel is critical to maintaining the performance and long life of a diesel engine. In order to produce and control the extremely high injection pressures common in a diesel, the injection pump components and nozzles are machined to extremely close tolerances - often measured in microns (one micron is 40 millionths of an inch). To prevent the premature

failure of these vital components, it is critical that diesel fuel be filtered to remove extremely small particles of foreign matter. The particles that a secondary or final fuel filter captures, for example, are in the range of 5-10 microns (.0002 - .0004"). To illustrate how small these tolerances are, consider:

- The naked eye cannot see particles smaller than 40 microns.
- A grain of sand is approximately 100 microns.
- A human hair is approximately 70 microns.
- A single grain of talcum powder is 10 microns.

The greatest enemy of diesel fuel injection components is water. Once water enters the fuel system, it will rapidly wear and oxidize steel components and lead to:

- Rusting and corrosion of components
- Governor/metering component failure
- Sticky metering components (both pump and nozzle)
- Injection component wear and seizure

Water contamination can exist in diesel fuel in three forms:

- 1) Emulsified water: Water is suspended in the fuel like oil and vinegar in salad dressing.
- 2) Free water: Water is separated from the fuel and usually is found on the bottom of fuel/storage tanks.
- 3) Dissolved water: Water has been chemically dissolved in the fuel, like sugar in coffee. The warmer the fuel, the more water will be dissolved, but as temperatures drop, the water will come out of the solution in the form of free water.

Diesel engines vary widely in their cetane requirements, and there is no commonly recognized way to measure this value. In general, the lower an engine's operating speed, the lower the CN of the fuel it can use. Large marine engines can tolerate fuels with Cn's as low as 20, while some manufacturers of high-rpm diesel engines specify 55 CN fuel. Using cetane improvers can increase Cetane Number (but not Cetane Index). These additives, usually organic nitrates, boost CN by 2 to 7 numbers, depending on the dosage and the type of base stock used.

Other influences that affect fuel efficiency:

- 1) Viscosity: Viscosity influences the spray pattern when the fuel is injected into the cylinder. Low-speed marine engines can use higher viscosity fuels than high-speed road-transport engines, and still run without excessive smoking. Minimum viscosity limits are imposed to prevent the fuel from causing wear in the fuel injection pump.
- 2) Low Temperature Flow: Unlike gasoline's, which have freezing points well below even the most severe winter temperatures, diesel fuels have pour points and cloud points well

within the range of temperatures at which they might be used. This presents no problem on vessels where heated storage can be arranged. Seasonal blending to control cloud point (the temperature at which wax separates from the fuel) is the refiner's assurance against field problems. In the winter, there is an increasing tendency to use flow improvers, polymeric additives that modify the wax structure as it builds up during cooling. These additives keep wax crystals small, so they can pass through the fine pores of fuel filters en route to the injector pump.

- 3) **Storage Stability:** In storage, diesel fuels are attacked by atmospheric oxygen, which can cause deposits of varnish, and for marine fuels containing residual components, asphaltic material. Antioxidants and dispersants are added to prevent such problems, while copper metal deactivators reduce the catalytic effects of screens and other parts. In the presence of water, bacterial action can cause a build-up of slime in the storage system, leading to filter plugging. Biocides are added to inhibit bacterial growth. In cold-weather areas, there is the risk of static electric charges building up during high-rate dispensing of distillate fuels. Refiners include antistatic additives in diesel blends to prevent explosions.
- 4) **Component Compatibility:** Diesel fuels are injected into the engine through precision pumps and fine injector nozzles. Dirt and water contamination must be avoided to protect these critical components. Specifications include tight limits on water and sediment, but some fuel marketers also install final filters at the nozzles of service station pumps to protect against dirt picked up in the distribution system. Depending on the crude source, diesel fuels contain various amounts of sulfur oxides on combustion. These can cause high rates of engine wear and rapid depletion of engine oil additives. Engine manufacturers often relate oil change intervals to the fuel sulfur content. Deposit build-up in engines is influenced by fuel quality. Fuels that leave a heavy carbon residue and contain excessive amounts of high boiling point materials are prone to cause engine deposits.
- 5) **Sulfur Content:** Sulfur content is the first diesel fuel property to be widely controlled by legislation aimed at limiting exhaust emissions. Sulfur is present in all crude oils and refined products. Sulfates are part of a diesel engine's particulate emissions; therefore, controlling fuel sulfur level reduces the level of sulfate pollutants.
- 6) **Water Content:** All diesel fuels contain small amounts of water. Hydro-carbon type and distribution, and bulk temperature control the amount that a fuel can hold. As temperature decreases, the amount of water dissolved in the fuel will also decrease and may lead to a water layer forming on the bottom of the storage vessel. Draining the tank regularly will minimize this layer and prevent bacterial contamination and the inadvertent pumping of water into the fuel system. Excessive water in a fuel system can cause corrosion, filter plugging and icing (in the winter).

By-Pass Oil Filtration

Marine engines and equipment operate in some of the most severe environments. It is paramount that engines operate efficiently and require as little down-time for maintenance as possible. Often, because the operating environment is so harsh, maintenance managers will have to change oil and filters earlier and more often to reduce engine wear. This, of course, increases operating expenses and increases the potential for environmental liability if a spill should occur. Technology will keep engine oil constantly clean while in operation dramatically extending the time between oil changes by hundreds of hours. Simply put, if the oil is clean and additives are maintained, the oil does not need to be changed.

Benefits of By-Pass Oil Filtration include the following:

- Safely extended oil drain intervals
- Reduced frictional engine wear
- Reduced new oil purchases up to 90%
- Reduced oil-related maintenance costs up to 90%
- Reduced downtime/improved productivity
- Additive levels that remain well within acceptable limits
- Better-maintained oil viscosity
- Improved oil circulation
- Decreased sludge and varnish deposits
- Cooler running engines and/or equipment
- Increased engine efficiency
- Payback typically in less than one year

In SAE Technical Paper 2001-01-1898 a test with a 1 micron bypass filter showed that “The recycler achieved an 8.9% reduction in fuel consumption...The effect of the recycler on the fuel consumption was considered to be mainly due to the action of the recycler in reducing formation of in-cylinder deposits and solid contaminants thus reducing engine friction and fuel consumption.” The authors explain: “Lubricating oil is... a significant contributor to combustion chamber deposits (CCD). Engine deposits exist on the piston surface, cylinder head, and intake-exhaust valves. The primary source of piston deposits is the lubricant, and oxidation of the lubricant is the primary cause of deposit formation. In cylinder, deposits consist of ash from the lube oil additives, carbon and absorbed unburned fuel and lubricating oil. The CCD can be a source of wear in engines, increased friction and hence increased fuel consumption. Piston crown land heavy carbon has been shown to increase oil consumption and deposits have been shown to increase as piston temperature increases above 250 degrees Celsius.”

In this SAE paper there is a comparison with a test of the same type of engine where a 6 micron filter was used and a 5% reduction in fuel consumption was measured (SAE Technical Paper 1999-01-1139). The authors conclude that the lower fuel consumption could be explained by the finer filtration in the 1 micron filter.

In SAE Technical Paper 2001-01-0699 a test of trucks equipped with 6 or 1micron bypass filters can be read: “It clearly shows that the lube oil recycler has reduced the fuel consumption rate.

This is attributed to the filtration of the recycler, which reduced the accumulation of the solid contaminants and formation of the deposits in cylinder. Thus the friction was reduced and energy loss due to friction was decreased.”



Figure 49. By-Pass Oil Filtration System

In Figure 49 a typical installation of a By-Pass Oil Filtration System on a Caterpillar C-15 engine. The gray canister contains a 1 micron filter cartridge and is mounted high on the engine next to the heat exchanger. Mounting the canister at this level aids in changing the filter cartridge as the oil in the canister drains back to the engine. Changing our oil on a time basis is safer than just guessing when to change it, but it is not very cost effective. To date, it has been common practice to change out your oil on a prescribed basis, based on manufacturer’s recommendations - like at 250 hours of run time. With the costs of oil going up all of the time, this can be an expensive practice, especially when there are and have been ways to take the guess work out of when you should actually be changing out your lubricant. Now, instead of a complete oil change including primary engine filters, simple change the canister cartridge at the 250 hour interval, take an oil sample and send it to be analyzed. The oil analysis report will give the recommendation when it’s time to perform an oil drain.

Engine oil is comprised of two parts – 85% of it is simply base stock and the other 15% of it is the chemistry that the oil company's add, that actually performs all of the critical functions of the lubricant. The reason we change out our engine oil is either because the oil has become too contaminated with particles and by-products of the combustion process of the engine, or because the chemistry in the oil has depleted to such a level that it's no longer in good enough shape to lubricate and help protect the internal components of the engine.

The chemistry in your oil is sacrificial in nature – it is designed to perform a function and then be depleted. It is normal that at the typical oil change interval on most engines, even with standard filtration, that the chemistry is still very much intact and most people actually change it when it still has much of its useful life remaining. What you would see though, if you tried to extend your oil change intervals out with no added filtration, is that the chemistry would hold up for a short period of time before depleting extremely rapidly and then your engine would be at risk of premature wear and tear.

When using a much finer secondary filtration system, the chemistry in the oil will actually last for a much longer time period. This happens because the bypass filter is actually keeping all of the products of combustion (soot, ash, dirt particles, acid, etc...) under control much better than the OE filters and as a result, the chemistry doesn't have to work as hard and actually does a much better job protecting the internal components for a much longer time period. The only change that you would hope to see on an oil analysis when using a 1 micron filter as opposed to the OE 40 micron filters is the ISO 4406 code drop down to levels that are actually cleaner than even brand new, bulk tank oil, even after 500-1,000 hours of run time.

The superior bypass filters will hold more contaminants than any other oil filter on the planet and will also remove moisture from your oil (which is a severe enemy of oil life), but it won't enhance or add to the oil's current additive package. The filter's whole job is to keep contaminants under control so that the chemistry can last safely for as long as possible. Expect to see oil change intervals extended out anywhere from 5-10 times. Bypass filters will keep the used lubricant anywhere from 6 – 10 times cleaner than brand new oil. This would be impossible to achieve without better filtration for all of the reasons mentioned above.

Extending oil changes minimizes waste oil and that is a great thing for the environment. Bypass systems eliminate a whole lot of man hours per oil change as it is much quicker to just change a cartridge than to drain an entire sump; this also means more uptime for a vessel and having superior filtration on your engines and hydraulics gives operators peace of mind just knowing that they've got that extra bit of insurance on their equipment at all times.

Systems work just as well on hydraulic systems, which often times cost more to maintain than engines. Best of all, this technology is not expensive. Return-On-Investment (ROI) is the key to

increasing profits. Bypass Oil Filtration systems can pay for themselves within the first year. Most companies already have the price of the paid for in their maintenance budget, requiring no additional capital investment.

Bottom Coatings

It is well known that a fouled hull reduces a ship's speed considerably. Nowadays this equates to increased fuel consumption and cost of operation. Owners, operators and managers are well aware of this and are taking steps to reduce fouling as much as possible. However, fouling is too often overlooked at the beginning in the weed or grass stage. Usually, by the time it is dealt with barnacles, clams, sponges, and kelp is growing in full force. What is all too often missed or disregarded is the effect of the very early stages of biofouling: microscopic fouling or biofilm, commonly referred to as SLIME.

Within hours of a clean hull being submerged in the sea, bacteria begin to accumulate on that hull, whether or not is it coated with biocidal antifoulants (AF) or silicone or other foul-release coatings (FRC) or anything else. In its early stages, this slime is hardly visible. Light slime has been shown to increase fuel consumption by 8% or more and a heavy slime can result in fuel consumption increases of 18% or more. The increase in power required to maintain a cruising speed can cause excessive wear to engines. Modern ship propulsion plants are not typically designed with the large power margins that earlier propulsion plants had.

As an example, a vessel that requires 200 gallons of fuel per day to maintain a cruising speed of 10 knots with a completely smooth and unfouled hull, the way it was at its first speed trials. If that vessel were to build up a thin layer of slime in a month and a thick layer of slime in two months, by the end of those two months of sailing, it would be requiring 220 gallons of fuel per day to maintain the same cruising speed. Taking fuel at \$6 per gallon, the slime build-up would cost an additional \$120 per day just to keep operating at the same service speed. Even if the fouling remained at that level, in a month it would have used \$3,600 more fuel than it would have if the hull were clean. Based on 250 days per year, the costs could add up to over \$30,000 in additional fuel costs.

Increased fuel costs cannot be ignored if the ships are to be kept running economically. These are the kind of numbers that are being ignored when an owner or operator repaints a ship with traditional antifouling paint or a foul-release coating, after launching or relaunching then pays no further attention to the underwater hull until it's time to drydock again in 2 ½ years. Ignoring slime is a costly mistake for any vessel owner or operator. It is a matter of concern to those responsible for budgets, costs, profit and loss, long term investment value and total ownership cost as well as the environmental impact.

Bulbous Bows

In the late 1950s research was undertaken to reduce the drag on large commercial cargo ships. Many different ideas were tried and continue to be tried today in the ongoing development of the science of Naval Architecture. With model testing and advanced knowledge of hydrodynamics, the bulbous bow was formulated typically giving a 5% reduction in fuel consumption over a narrow range of speed and draft. This was significant for a large ship crossing vast oceans, at a time when the cost of fuel was rising.

On the West Coast of the United States where the fishing fleets run great distances over open ocean from California to Alaska, the desire for economy spurred optimization of the bulbous bow. Although available in many shapes and sizes, generally the bulb looks like a section of large diameter pipe with a domed end sticking out of the bow of the boat, underwater. The picture above is a steel 113" Bering Sea crabbing vessel. The vessel was constructed in 1993 and was not designed or built with a bulbous bow. The bulb shown was designed by a naval architect and assembled in steel and welded to the vessel. It actually is a large pipe with a domed forward section. The reinforcing gusset can be seen angled down from the waterline. The owners of the vessel state the boat handles better in a seaway, does not slam into head seas, and is faster at the same rpm providing a fuel savings.

In the late 1980s the University of British Columbia, utilizing the B. C. Research Ocean Engineering Center, initiated model test work on 60 foot fishing seiners. Since that time, B.C. Research has become the center of bulbous bow technology, doing model test work for yacht builders and commercial yards alike as well as for designers and researchers. Results have shown that the continuous displacement speeds run for days at a time, coupled with the limited change of draft, make vessels as small 45 feet applicable. Below this size the bulb's effectiveness seems to lessen. Over 45 feet the results are adequate and closer to the 60 foot size real gains are being achieved. This may be due to the lack of detailed research conducted on vessels under 45 feet or just because of the stockier hull forms required in these really small ships.

A bulbous bow, whether incorporated into the vessel when constructed or as a retrofit, will reduce fuel consumption 12% to 15%. The reduced fuel consumption will provide greater range or a slightly higher speed for the same power applied. The greatest amount of benefit will be at the high end of the semi-displacement speed range, reducing as your speed decreases. At higher speeds wave making resistance accounts for the greater portion of the drag, and the slower you go proportionally more of the resistance is taken up by wetted surface drag. At low speed (around 6 knots and lower) the bulb will even cause an increase in drag because of its greater wetted surface area. At a low speed the added power consumption is negligible and generally little time is spent in this speed range.

In addition, you will find increased sea keeping ability due to dampening of the pitching motion. When charging into head seas there is the chance of slamming the bulb on the troughs, but this is limited to a very narrow range of wave train and heading. A slight change in direction and/or speed will cure this ill-effect.



Figure 50. Bulbous bow of a fishing vessel.

Although much is known about the bulb, much of its functions are still in dispute. To say that on a hydrodynamic level, the destructive interference of the primary and secondary wave trains causes an overall reduction in drag which is beneficial to the vessels resistance characteristics would be true. On a more physical level, that the water coursing over the top of the bulb is exerting a downward pressure that is keeping the stern from squatting. The downward pressure produces a flatter trim, causing the vessel to run with less resistance. Still others would argue the finer points of laminar flow, with no clear conclusions. In any case, it is a fact that bulbs do work and in some cases reduce resistance as much as 25%. Their proportions are derived from the features and dimensions of the vessel itself. The diameter (volume) is a direct result of the hull midship area. The length is determined by the stem profile, as the farther forward the bulb extends the more leverage it has but is generally kept shorter than the bow overhang. The section shape may be a modified ellipse to reduce pounding in head seas. The vertical placement is calculated so the bulb is just below the surface where it will create a wave in front of the ship interfering with the natural wave train of the vessel, creating a wave hollow where a crest should be. In this way the vessel will run flatter and the overall wave height will be reduced. The vessel will pitch less which will cause fewer disturbances in the water. Any time a vessel can be moved through the water with less waves and overall disturbance to the surface less power has been transmitted to the water to create those waves.

Vessels over sixty feet should consider the design and implementation of a bulb. It can be a relatively inexpensive addition considering the potential gains in fuel efficiency. Steel vessels have the advantage as the cutting and welding can be completed quickly. Other materials such as fiberglass may require cutting and bonding to the hull with additional fairing work that may be required such as in the picture below.

Kort Nozzles

The advantages of Kort Nozzles are well known for towing vessels such as tugs and fishing boats. The first Kort Nozzles were fitted in 1935 and have earned the reputation for increased the pulling power and increasing fuel efficiency. The thrust increase available to vessels working at low speed of advance is now common knowledge; however, one size does not fit all. In most all cases each nozzle and prop must be engineered to fit each vessel application.

Tugs, trawlers, dredgers and offshore supply vessels are typical of the application where a Kort nozzle can provide up to 25-30% improvement in thrust at low speed. This allows a reduction in installed power for a given performance. A fishing vessel, for example, can work larger gear in deeper waters or maintain speed in bad weather as proven by the many thousands of trawlers fitted worldwide. Kort Steering Nozzles worldwide provide excellent maneuverability, giving a positive response to small angles of helm when going ahead or astern.



Figure 51. Ducted propeller with Kort nozzle

The key to vessel performance is the correct design of propeller and Kort Nozzle in combination and Kort has the expertise and experience to provide this for both fixed or controllable pitch propeller systems. Two recent conversions prove that the increased trawling thrust from a Kort Nozzle system can reduce fuel consumption. Average figures from weekly trips and show a

reduction of 20% in fuel consumption/hour when trawling. Overall it is not uncommon to see a 15% reduction in annual fuel bills taking steaming into account.

A Kort Nozzle system gives 20-25% increase in thrust when towing. A vessel with 800 bhp and 2000mm open propeller achieves 8.6 tonnes. 8.6 tonnes can be achieved using 640 bhp with a Kort Nozzle system. A 20% reduction in engine power for the same towing thrust! The increases in performance apply for all engine sizes. In fact the Kort Nozzle system provides more thrust with either fixed pitch or CP propellers has been proved beyond doubt. A 10m vessel with 100 hp or a 40m vessel with 2000 hp the benefits of the Kort Nozzle are the same.

The high price of fuel will continue to drive the quest for more fuel efficient vessel operations and propulsion nozzles must be considered. In most cases a vessel's hull will outlast the main propulsion engine and many vessels are repowered at least once and sometimes twice in their lifetime. During the repower project this is the time to fit a nozzle and establish the proper drive train. Installing a nozzle on most commercial vessels is a relatively straight forward project that most commercial shipyards can undertake.

Hydrogen Supplement Fuel

With ever increasing costs of fuel and constant concerns of exhaust emissions on our environment, the best solution to both these problems is the addition of a highly combustible fuel additive to the combustion of diesel fuel. This is done by separating water into hydrogen and oxygen by electrolysis and injecting the gaseous mix into the air flow system of the engine as a supplement to the diesel fuel. After the introduction of hydrogen and oxygen from electrolysis the product after combustion is increased oxygen. Therefore, the reduction of exhaust emissions is a direct effect on our environment. Cleaner air and the reduction of CO2 emissions is a large concern worldwide. Refining the scientific method of the electrolysis of water and introducing this to diesel engines provides a simplified way to make today's engines more efficient for the future!

Benefits:

- Improve Diesel Fuel Combustion
- Increased Fuel Efficiency
- Reduced Exhaust Emissions
- Reduced Soot in Engine Lube Oil
- Smoother Running Engines
- Longer Engine Life
- Reduced Maintenance and Repair Costs
- Added Environmental Responsibility

Hydrogen burns more rapidly than hydrocarbon fuels because it is smaller and enters combustion reactions at higher velocity, has lower activation energy, and incurs more molecular collisions than heavier molecules. These characteristics make it possible to use mixtures of hydrogen with conventional hydrocarbon fuels such as gasoline, diesel and propane to reduce emissions of unburned hydrocarbons. Transition from fossil fuels to renewable hydrogen by use of mixtures of hydrogen in small quantities with conventional fuels offers significant reductions in exhaust emissions.



Figure 52. Fuel cell system applied on a fishing vessel

Mixing hydrogen with hydrocarbon fuels provides combustion stimulation by increasing the rate of molecular-cracking processes in which large hydrocarbons are broken into smaller fragments. Expediting production of smaller molecular fragments is beneficial in increasing the surface-to-volume ratio and consequent exposure to oxygen for completion of the combustion process. Relatively small amount of hydrogen can dramatically increase horsepower and reduce emissions of atmospheric pollutants.

Emulsified Diesel Fuel

Emulsion Fuel is water and petroleum blended at a sub-micron level. In basic terms, emulsion fuel (EM fuel) is an emulsion of fuel and water, yielding a 100% new fuel. Emulsified diesel fuel is made up of at least three components, diesel, water and additive (surfactant). Depending on the application the amount of water used can vary from 20% to as high as 40%. Typically, 10 to 20% water content is the best we have seen in the marketplace for internal combustion engines.

The additive represents only 1% of the final product. When water-emulsion fuel burns, water droplets in the fuel rapidly rise in temperature, atomizing the surrounding oil into diffuse minute particles. The combustible surface area of oil particles and air increases in orders of magnitude, leading to more efficient fuel combustion and less particulate matter.

Emulsification results in smaller molecules of bonded water and fuel. Explosive vaporization occurs when the fuel is injected into the engine, fragmenting the droplets further. As a result, the emulsified fuel burns more completely than straight diesel. With straight diesel, not all PAH (Polycyclic Aromatic Hydrocarbons) are consumed during combustion. It is this unburned PAH that results in Particulate Matter (PM). With Emulsion Fuels, diesel engines instantly achieve a substantial reduction in their emissions of PM, and NOx. NOx refers to NO (Nitric Oxide) and NO2 (Nitrogen Dioxide). The typical performance of Emulsion Fuel would lead to up to 80% smoke reduction, up to 60% PM reduction up to a 50% reduction in NOx.

Blending units required for the production of diesel oil emulsions, fuel oil emulsions, emulsified biodiesel and residual oil emulsions are vastly different in design and application. One feature common to these units is that they are relatively inexpensive, simple to manufacture, and operate with minimal service and maintenance requirements. Blending units are generally automated self-contained units that consist of a series of mixers, motors, pumps, meters and injectors, in which water, base fuel, and additives are processed.

Once the system is placed onboard producing emulsified fuel products is relatively simple. The blending unit computer measures, monitors and controls a variety of operating parameters, including temperatures, pressures, flow rates and motor variables. If any of the parameters vary from preset operational limits, an alarm will notify the operator. If a change is not made within a set period the unit will automatically cease production.

Fuel emulsion done correctly can reduce diesel fuel costs and realize the savings from day one. The return-on-investment can be calculated easily and a vessel of any size will recover the cost of equipment in a short period of time. One thing to note is the engine manufacturers are working on their own fuel emulsion systems. MTU has recently released their plans in this emerging field. There are a variety of systems available from smaller portable units to large stationary systems for vessels and land based operations.

Fuel Reduction Case Study

In this particular project to reduce the fuel consumption a 60' Western style steel stern trawler is being used. The trawler is of 200,000 lb displacement, 26' beam, 7' draft and built in 2003. At the time the vessel was fitted with the most current known technologies and equipment where incorporated to provide the most efficiency possible. The vessel is equipped with a 3406 Caterpillar diesel with a 7:1 reduction gear driving a 60' diameter four blade propeller inside a Kort Nozzle. The Kort Nozzle is a shrouded, ducted propeller assembly for marine propulsion that increases the efficiency of a propeller by as much as 30%. Tugboats are the most common application for Kort Nozzles as highly loaded propellers on slow moving vessels benefit the most, the reason for the adaptation to trawlers.

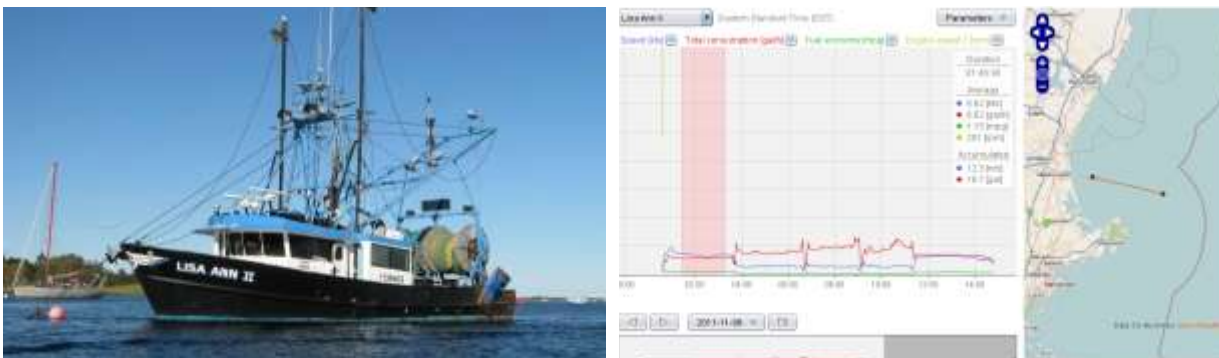

Figure 53. VMS onboard a fishing vessel.

To improve the fuel efficiency and reduce fuel consumption the baseline of vessel operations must first be established. A fuel consumption meter, shaft rpm collar, GPS receiver and data processor was installed and tied into the main ship computer. This equipment provides accurate real-time information regarding actual fuel consumption, shaft rpm and vessel speed. The vessel will be operated normally for a determined period of time to establish a realistic operational baseline to establish fuel consumption. During this time the operator is not provided any information or access to metering displays in an effort to gather accurate baselines. In vessels with two or more engines this is the only true method of confirming equal load sharing and validated existing (if available) computer performance settings.

Vessel operations are monitored and graphed as shown in Fig. 4-1. This particular day was a duration of fourteen hours and nine minutes which consisted of the run to the grounds, three sets of towing an otter trawl with 600 lb. doors, and the return to port. Notice how the speed line (blue) and the fuel consumption (red) are very close to each other in the beginning (outbound) of the graph and at the end (Inbound). During the three tows the fuel burn is increased while showing a variable consumption rate. The shaded area shown in pink can be set to anywhere on the graph and can be used to set routes that can be compared over time. This shaded area shows the data to the right with a duration of one hour and forty-six minutes at 6.92 knots and 6.02

gallons per hour. This technology allows the versatility to test and monitor any changes made in the ship and to operate from that point for the maximum efficiency possible. A fleet manager will be able to monitor a vessel at sea from his desktop from anywhere in the world. Currently the data is transmitted by cell phone data transmission when the vessel is within cell range and is proving to be fully functional up to 25 miles. In the event that the transmission feed is interrupted (out of range) the information is stored on the computer and transmitted when cell connection is re-established. The vessel can also be tracked with the cursor moving over the graph and observing the position on the map allowing vessel managers to further monitor fishing activities on the grounds. Data transmission via satellite is available and will allow tracking and monitoring of vessels outside of cell range.



Figure 54. Fuel consumption data logging.

An on-board hydrogen generator is installed that produces up to eight liters a minute of HHO, commonly referred to as Brown's gas, from distilled water. The mix of hydrogen and oxygen is injected into the air intake of the engine. The system is self-contained in a fiberglass case. This system operates on 12 DC and in this case the power is drawn from the diesel generator 120/240 volt AC. A 12 volt ninety amp power supply/converter provides the amperages required to produce the required HHO that may range from 38 to 72 amps. There is no hydrogen being stored under pressure and all the gas produced is immediately taken into the engine. The system turns on and off by the engine's oil pressure so there is no danger of the system operating without the engine running.

Exhaust Emissions Reduction

The reduction of diesel engine exhaust is one of the key benefits of the Hydro-Box™. The test engine is a 7.2 liter Caterpillar diesel attached to a dynamometer to control rpm and torque settings. The following table shows the RPM setting and the effects with HHO on and off, proving that adding hydroxy contributes to a more complete burn, drastically reducing exhaust emissions. The test reduced NOX by 72.6% and Co2 by 68%.

Idle	No HHO	1 lpm HHO	% change	2 lpm HHO	% Change	3 lpm HHO	% Change
E.G.T.	238°	217°	-8.8%	163°	-31.5%	157°	-34.0%
O2	19.5%	19.9%	2.1%	20.1%	3.1%	20.5%	5.1%
CO	230	110	-52.2%	130	-48.5%	97 ppm	-57.8%
NO	273 ppm	185 ppm	-32.2%	123 ppm	-54.9%	77 ppm	-71.8%
NO2	66 ppm	42 ppm	-36.4%	46 ppm	-30.3%	34 ppm	-48.5%
NOX	339 ppm	227 ppm	-33.0%	169 ppm	-50.2%	111 ppm	-67.3%
CO2	1.1%	0.8%	-27.3%	0.7%	-36.4%	0.4%	-63.6%
1600 RPM	No HHO	1 lpm HHO	% change	2 lpm HHO	% Change	3 lpm HHO	% Change
E.G.T.	534°	441°	-17.4%	435°	-18.5%	412°	-22.9%
O2	12.50%	15.70%	-22.6%	16.10%	28.8%	18.10%	44.8%
CO	200 ppm	121 ppm	-39.5%	128 ppm	-36.0%	80 ppm	-60.0%
NO	1,028 ppm	689 ppm	-33.0%	612 ppm	-40.5%	378 ppm	-63.2%
NO2	62 ppm	46 ppm	-25.8%	39 ppm	-37.1%	25 ppm	-59.7%
NOX	1,090 ppm	735 ppm	-32.6%	651 ppm	-40.3%	403 ppm	-63.6%
CO2	6.20%	3.90%	-37.1%	3.60%	-37.1%	2.10%	-66.1%
2000 RPM	No HHO	1 lpm HHO	% change	2 lpm HHO	% Change	3 lpm HHO	% Change
E.G.T.	814°	743°	-8.7%	743°	*8.7	673°	-17.3%
O2	8.10%	13.10%	62.0%	13.20%	63.0%	17.30%	113.6%
CO	1408 ppm	846 ppm	-39.1%	533 ppm	-62.1%	473 ppm	-66.4%
NO	1055 ppm	658 ppm	-37.6%	648 ppm	-38.6%	381 ppm	-71.0%
NO2	42 ppm	46 ppm	9.5%	46 ppm	9.5%	23 ppm	-45.2%
NOX	1097 ppm	704 ppm	-33.8%	694 ppm	-36.7%	407 ppm	-70.0%
CO2	9.50%	5.80%	-40.0%	5.70%	-40.0%	2.70%	-71.6%
2400 RPM Full	No HHO	1 lpm HHO	% change	2 lpm HHO	% Change	3 lpm HHO	% Change
E.G.T.	737°	629°	-14.7%	619°	-16.0%	702	-4.8%
O2	10.30%	14.60%	36.5%	15.00%	45.6%	17.60%	70.9%
CO	269 ppm	83 ppm	-69.1%	78 ppm	-71.0%	101 ppm	-62.5%
NO	1032 ppm	695 ppm	-36.0%	668 ppm	-35.3%	277 ppm	-73.2%
NO2	52 ppm	46 ppm	-16.4%	43 ppm	-17.3%	20 ppm	-61.5%
NOX	1084 ppm	741 ppm	-35.0%	711 ppm	-34.4%	297 ppm	-72.6%
CO2	7.80%	4.70%	-38.2%	4.40%	-43.6%	2.50%	-68.0%

Opportunities

Currently, we have the ability to reduction diesel fuel consumption dramatically, perhaps by as much as 45% in some cases. This is achieved by the combinations of fuel emulsion, hydrogen injection, and on-board fuel management analytic systems. These technologies also have capability to reduce NOX emissions by as much as 90%. By-pass oil filtration systems can extend oil drains by as much as 5 or more times and help protect the engine guarding against costly maintenance or break downs. Vegetable based lube and hydraulic oils reduce risks to the environment when spilled and are actually a higher grade of lubrication than petroleum based oils and grease. Bilge water oils are collected by a material that becomes a solid that becomes non-hazardous for disposal. And, natural materials and oil eating microbe's for cleaning and degreasing. There are problematic barriers to market. Fuel supply companies do not want the vessels using less fuel. They will promote all kinds of propaganda such as fuel emulsion and hydrogen will destroy the engine and void engine warranties. The service companies that change oil do not want By-Pass Oil Filtration as they may lose much of their revenue performing regular oil changes. Engine companies lobby the governments for emission standards in new model engines so they can sell new replacements. Governmental approval of devices that may bring an older engine to compliance may not happen. These new technologies are not even considered by the US EPA as an emerging technology at this point, mainly due to they are too simple and very cost effective. With all this said there are those that are moving ahead and approaching the barriers one project at a time. There are tremendous opportunities for the vessels and the companies that own them to increase their bottom line by going "Green". It may only take a few vessels and one or two companies (fleets) to implement the fuel saving technologies and methods and a whole new industry would emerge with the creation of new "Green" jobs.

2. Material and information collected

All the material collected has been sent to the JRC in three different updates through CNR – ISMAR ftp. Furthermore, for very interesting materials, a continuous streaming of information by email has been maintained.

List of Associations

INTERNATIONAL INSTITUTE OF FISHERIES ECONOMICS AND TRADE

International group of economists, government managers, private industry members, and others interested in the exchange of research and information on marine resource issues.

Annual subscription payment. (from 75 \$/year or standard users)

ONLUS association.

<http://oregonstate.edu/dept/IIFET/>

EUROPEAN FISHING TECHNOLOGY PLATFORM

The EFTP initiative is meant for identifying the key challenges for (at least the first quarter) of the 21st Century for fisheries and fishing technology, and to formulate the RTDI requirements for meeting future challenges within the sector. Moreover, achieve consensus on future research directions and to support sufficient mobilization from public and private technical, human and financial resources. Not updated. **It seems to be not operative.**

<http://www.eftp.eu/energyefficiency.htm>

CENTRAL INSTITUTE OF FISHERIES TECHNOLOGY

The Central Institute of Fisheries Technology (CIFT) set up in 1954 is the only national center in the country where research in all disciplines relating to fishing and fish processing is undertaken. The institute started functioning at Cochin in 1957. Research centers function at Veraval (Gujarat), Visakhapatnam (AP), Burla (Orissa), Mumbai (Maharashtra). Private association, focused on fishing technology and few other issues related to fisheries.

<http://www.cift.res.in/index.php>

ORGANISATION FOR ECONOMIC CO-OPERATION AND DEVELOPMENT (OECD)

OECD's work is based on continued monitoring of events in member countries as well as outside OECD area, and includes regular projections of short and medium-term economic developments. The OECD Secretariat collects and analyses data, after which committees discuss policy regarding this information, the Council makes decisions, and then governments implement recommendations. OECD is funded by its member countries.

http://www.oecd.org/statisticsdata/0,3381,en_2649_37401_1_119656_1_1_37401,00.html

NORTHWEST ATLANTIC FISHERIES ORGANIZATION (NAFO)

NAFO is an intergovernmental fisheries science and management body.

<http://www.nafo.int>

NORTHEAST CONSORTIUM

Develop partnerships between commercial fishermen and scientists, educators, and coastal managers; Enable commercial fishermen and commercial fishing vessels to participate in collaborative research; Help bring fishermen's information, experience, and expertise into the scientific framework needed for fisheries management.

<http://www.northeastconsortium.org/>

AZTI-TECNALIA

AZTI-Tecnalia, a Technological Centre specialised in Marine and Food Research, is a non-profit organization, whose objective is the social development and the improvement of competitiveness in its area of influence by means of technological Research and Innovation.

<http://www.azti.es/en/>

INSTITUTE OF BALTIC SEA FISHERIES

The Institute for Baltic Sea Fisheries (OSF) is the successor of the Institute of Marine Research of the GDR (1953-1991). The prime tasks are conducting research to establish the scientific basis for advising in political decision in fishery political decisions of the Baltic Sea.

<http://www.vti.bund.de/en/startseite/institutes/baltic-sea-fisheries.html>

OCEAN2012

<http://www.ocean2012.eu/>

INTERNATIONAL INSTITUTE OF FISHERIES ECONOMICS AND TRADE

<http://oregonstate.edu/dept/IIFET/>

DTU AQUA – NATIONAL INSTITUTE OF AQUATIC RESOURCES

DTU Aqua – National Institute of Aquatic Resources – is an institute at the Technical University of Denmark (DTU). DTU Aqua was previously known as DIFRES - Danish Institute for Fisheries Research.

<http://www.aqua.dtu.dk/English/About.aspx>

2.1 News

Small pelagic: a strategic resource for Africa

<http://agritrade.cta.int/Publications/Interviews/Small-pelagics-a-strategic-resource-for-Africa>

Queensland's commercial fishing industry and Fisheries Queensland have finalized a plan to help build the profitability of the state's reef line and Spanish mackerel fisheries.

<http://www.worldfishing.net/news101/new-plan-gives-fisheries-a-boost>

Uta Bellion, director of the Pew Environment Group's European Marine Programme and coordinator of OCEAN2012, has issued a statement on the European Commission's proposal for reform of the European Union's CFP.

<http://www.worldfishing.net/news101/ocean2012-response-to-cfp-proposals>

NGOs and OCEAN2012 oppose an increase in de minimis aid

<http://www.ocean2012.eu/publications/29-no-increase-in-blind-spending>

Eco-friendly alternative to bottom trawling for India

<http://www.worldfishing.net/wf-june-2011/trawling-and-fishing-gear/eco-friendly-alternative-to-bottom-trawling-for-india>

Research Fellowships and Conference Sponsorship - Co-operative Research Programme - The OECD Co-operative Research Programme (CRP) invites applications for its 2012 Research Fellowships and Conference Sponsorship.

http://www.oecd.org/document/40/0,3343,en_2649_33903_42629992_1_1_1_1,00.html

INFOFISH is the leading source of marketing support for fish producers and exporters in the Asia-Pacific. INFOFISH undertakes consultancies on all aspects of fisheries - pre-harvest, harvest and post-harvest.

<http://www.infofish.org/>

NH Sea Grant begins GREEN-FIT Project to Address Fuel Savings

<http://nhsustainablefisheries.blogspot.com/2011/06/nh-sea-grant-begins-green-fit-project.html>

Project Enerpesca

A project on energy efficiency and development of solutions of I + D + i, led by the Association of Fishermen of St. Martin Bueu for the responsible use of energy, which contributes to sustainable fishing in the entire chain of production

<http://www.enerpesca.org/>

Project ESB Cataluña: Mejora de la eficiencia, la sostenibilidad y el beneficio de la flota pesquera de arrastre catalana

The objective of this project is to determine, through testing and certification in real situations and on a sample of five ships, technological improvements, innovations and actions to be implemented in the trawl fleet, which can actually be a Catalan savings, and to extrapolate measurements to the rest of the fishing industry.

http://www20.gencat.cat/portal/site/DAR/menuitem.54dbc9033f51a110bd82c410b0c0e1a0/?vgnextchannel=6d97a061a60fd210VgnVCM1000008d0c1e0aRCRD&vgnnextfmt=default&vgnextoid=6d97a061a60fd210VgnVCM1000008d0c1e0aRCRD&newLang=es_ES

Project Peixe Verde (Green fish)

Peixe Verde is going to work in multiple options in a systematic way, looking for solutions for the serious problem that the ascent of the price of the petroleum supposes for the fishing sector (with 45.000 direct employments in Spain). The first big succes has been to promote the best consortium to carry out an R+D that allows to look for big future (as the hydrogen) solutions and good solutions of short term at the same time (as the reduction of consumptions in the ships) In the menu of the left you can find more information.

http://www.peixeverde.org/peixe_org_eng/

Energy-Saving Propeller Boss Cap Fins System

TOKYO— Mitsui O.S.K. Lines, Ltd. (MOL; President: Koichi Muto) and MOL Techno-Trade, Ltd. (MOL Tech; President: Hidehiro Harada) today announced that the energy-saving Propeller Boss Cap Fins (PBCF), developed by MOL, West Japan Fluid Engineering Laboratory Co., Ltd., and Mikado Japan, Ltd., and sold by MOL Tech, has now been ordered for 2,000 vessels worldwide. The PBCF is an energy-saving device attached to the propellers of a vessel. It breaks up the hub vortex generated behind the rotating propeller, resulting in a decrease of more than 9,000 tons of CO2 emissions per year due to a 3-5% reduction in fuel consumption by a large-scale containership.

<http://www.molhk.com/news/detail/233>

IBIA recognises LNG as fuel for ships

At the recent annual convention of the International Bunker Industry Association, held in Barcelona, the IBIA board announced its official decision to “become more closely engaged in LNG matters”.

<http://www.motorship.com/news101/ibia-recognises-lng-as-fuel-for-ships>

Fuel subsidies for fisheries

EU Member States provide fuel subsidies for fishing activities both directly through subsidies and indirectly through fuel tax exemption. These are environmentally harmful subsidies and Seas At Risk is calling for a shift from such subsidies to incentives for the transition to low-impact fisheries.

<http://www.seas-at-risk.org/n3.php?page=126>

Making the CFP work for Low Impact Fisheries

Brussels, 22nd November 2011. In the context of the reform of the Common Fisheries Policy (CFP) SAR is hosting a lunch time event at the European Parliament in Brussels.

http://www.seas-at-risk.org/n2_more.php?page=447&KT_back=-1

Greenhouse gas emissions & fisheries

The global increase in fuel-intensive fisheries has led to a substantial increase in CO2 emissions from fishing vessels. In general, fuel-intensive (active) fishing techniques not only contribute more to climate change than less fuel-intensive (passive) fishing techniques, but they also have significant direct negative impacts on the marine ecosystem.

<http://www.seas-at-risk.org/n3.php?page=138>

The down side of dual fuel, by Rolls-Royce

According to Rolls-Royce Marine, dual fuel gas/diesel engines are not a good option, either engineering-wise or economically, compared with the Bergen lean-burn pure-gas solution.

<http://www.motorship.com/news101/the-down-side-of-dual-fuel,-by-rolls-royce>

New report on EU fishing subsidies

A report released by Oceana shows that a total of at least €3.3 billion in subsidies were available to EU fleets in 2009. This is more than three times the publicly available figures referenced in the past, which only include EFF data. Moreover, ‘Total subsidies to the fishing sector are equivalent to 50 percent of the value of the total fish catch by the EU’ in 2009 (€6.6 billion).

<http://agritrade.cta.int/en/content/view/full/7425>

HK Launches New Pulling Winches for Auxillary Functions

HK presents new product range in pulling winches: hydraulic and electrical version for rated line pull of 4.5, 5.4, and 6.8 daN. CHW PRO series winch features compact structure, easy operating, 2-stage planetary gear train, spring applied hydraulic released disc brake, counter balance valve, manual or air clutch, provides high efficient working performance and most reliable safety.

<http://www.ship-technology.com/contractors/handling/hk/press15.html>

Batteries open the door to hybrid systems

Dutch company ESTechnologies has introduced what it says are the first marine lithium-polymer batteries with Lloyd's Certificate. The battery range is designed and certified for marine applications and large energy storage systems. Lithium polymer batteries are claimed to be cost effective and environmentally friendly.

<http://www.motorship.com/news101/batteries-open-the-door-to-hybrid-systems>

Scottish funding for fishing communities

The European Fisheries Fund (EFF) has made £4.2m of funding available to help fragile fishing communities across Scotland. Under Axis 4 of the EFF, the money will be made available to 13 local councils, which will need to co-finance the amount granted in order to make total funds available up to £7.6m

<http://www.worldfishing.net/news101/new-scottish-funding-available>

Grants go toward algae biofuels research in US, Japan

A better understanding of how algae can be used to make biofuels is the aim of a new joint project between the University of California (UC) at Davis and the University of Tokyo, Japan. It is one of four new grants, jointly funded by the US National Science Foundation and the Japan Science and Technology Agency, to develop environment-friendly fuels and reduce pesticide use.

<http://fis.com/fis/worldnews/worldnews.asp?l=e&ndb=1&id=49171>

Fuel savings for kite propelled fishing vessels

The commercial fishing industry may be set to benefit from innovative new kite technology – aimed at providing fuel savings for vessel operators.

<http://www.worldfishing.net/news101/fuel-savings-for-kite-propelled-fishing-vessels>

TecnoVeritas Hosts Seminar

TecnoVeritas, in cooperation with the Shanghai Society of Naval Architects & Marine Engineers (SSNAME), held a seminar titled 'A tool for ship energy optimization compliant with IMO MEPC.1/Circ684' on November 29 at Shanghai New International Expo Centre (SNIEC), during the most representative and largest maritime event in Asia, Marintec China 2011.

http://www.ship-technology.com/contractors/propulsion/tecnoveritas/presstecnoveritas-hosts-seminar.html?WT.mc_id=DN_PR

New maritime and fisheries fund proposed

In Brussels the European Commission (EC) has proposed a new fund for the EU's maritime and fisheries policies for the period 2014-2020: the European Maritime and Fisheries Fund (EMFF). The EMFF will use EUR 6,700 million to help deliver the ambitious objectives of the reform of the Common Fisheries Policy and to help fishermen in the transition towards sustainable fishing, as well as coastal communities in the diversification of their economies.

<http://fis.com/fis/worldnews/worldnews.asp?l=e&ndb=1&id=48167>

Council adopts integrated maritime policy regulation

The European Council yesterday adopted a regulation establishing an EU programme to further promote the development and the implementation of the EU's integrated maritime policy.

<http://fis.com/fis/worldnews/worldnews.asp?l=e&ndb=1&id=47953>

Impact of climate change on fisheries

A new study led by University of British Columbia researchers has revealed how the effect of climate change will create a huge drop in profitability for fisheries unless action is taken now.

<http://www.worldfishing.net/news101/impact-of-climate-change-on-fisheries>

2.2 Events

Description	Website	Location	Topic	Date
IMAM 2011	www.imam2011.it/	Genoa Italy	Naval Engineering	Sept. 13 – 16 2011
NETA2011	www.icecemeeting.org/2011/neta/	Yichang China	Wind, Solar Energy	Sept. 16 – 19 2011
Icelandic Fisheries Exhibition 2011	www.icefish.is/	Smàrinn, iceland	Fishing Technology	Sept. 22 – 24 2011
MARINE TECH Summit 2011	www.bitconferences.com/mts2011/default.asp	Busan, South Korea	Naval Engineering	Sept. 25-27 2011
International Conference on Ship Efficiency	www.ship-efficiency.org/2011/programme.html	Hamburg Germany	Naval Engineering	Sept. 26 - 27 2011
MARINE 2011	http://congress.cimne.upc.es/marine2011/frontal/default.asp	Lisbon Portugal	Naval Engineering	Sept. 28 – 30 2011
Danfish	www.danfish.com	Aalborg Denmark	Fishing Technology	Oct. 12-14 2011
Gas Fuelled Ships Conference	www.motorship.com/gfsconference	Rotterdam, Netherlands	Naval Engineering	Oct. 26 – 27 2011
DEMAT 2011	www.uni-rostock.de/demat/demat_es.htm	Split Croatia	Fishing Technology	Oct. 26 – 29 2011
ITECHMER 2011	www.itechmer-orient.com/english/home.html	Lorient France	Fishing Technology	Oct. 27 – 29 2011
6th World Fisheries Congress 2012	www.6thwfc2012.com/key-dates	Edinburgh Scotland	Fishing Technology	May 7-11 2012

Description	Website	Location	Topic	Date
EXPO PESCA & ACUIPERU	http://www.thaiscorp.com/expope_sca_new/site/index.php	Lima, Peru	Fishery	Nov. 10 – 12 2011
65th Canadian Conference for Fisheries	http://www.phys.ocean.dal.ca/ccf/fr/	Moncton, New Brunswick, Canada	Fishery	Jan. 5-7 2012
EXPO 2012:	http://www.bie-paris.org/site/en/expos/yeosu-2012.html	Yeosu, Korea	Fishery	May 12 – 14 2012
Motorship Propulsion & Emissions Conference 2012	http://www.propulsionconference.com/	Hamburg, Germany	Engineering	May 23 – 24 2012
National Fish and Wildlife Conservation Congress	http://www.nfwcc.com/index.php	Westin Ottawa, Canada	Fishery	May 27 – 31 2012
SeaExpo Turkey 2012	http://www.seaexpoturkey.com/seanew/eng/index.html	Istanbul, Turkey	Fishery	June 14 – 17 2012
Nor Fishing	http://www.nor-fishing.no/index.php?page=hjem&hl=en_US	Trondheim, Norway	Fishery	Aug. 14 – 17 2012
Annual Meeting of American Fisheries Society	http://www.afs2012.org/	Minneapolis, Minnesota, USA	Fishery	Aug.19 – 23 2012
Fisheries & Seafood Expo		Dalian, China	Fishery	Nov. 6 – 8 2012
International Fisheries & Seafood Exposition	http://www.sifse.com/en/index.asp	Shanghai, China	Fishery	Dec. 8 – 10 2011
7IFOMC	http://www.ifomc.com/index.php	Viña del Mar, Chile	Fishery	Apr. 8 – 12 2013
NAV 2012	http://www.atenanazionale.it/nav/index.php/NAV/NAV2012	Naples, Italy	Engineering	Oct. 17 – 19 2012

<u>Description</u>	<u>Website</u>	<u>Location</u>	<u>Topic</u>	<u>Date</u>
Pacific Fisheries Technologists Conference	http://pftfish.net/	Anchorage, Alaska	Fishery	Feb.12–15 2012
Marine Tech Summit 2012	http://www.bitconferences.com/MTS2012/#	Dalian World Expo Center, China	Engineering	Sept. 20 – 23 2012
Marine Culture and Fisheries 2012	http://www.bitconferences.com/WCMF2012/default.asp	Dalian World Expo Center, China	Engineering	Sept. 20 – 23 2012
Pacific Fisheries Technologists Conference	http://pftfish.net/	Anchorage, Alaska	Fishery	Feb.12–15 2012
The Ship Propulsion Summit	http://www.wplgroup.com/aci/conferences/eu-mpa1.asp	Singapore	Engineering	Mar. 14 – 15 2012
MarinFish	http://www.marinfish.org/index.html	Negombo, Sri Lanka	Fishery	Aug. 23 – 24 2012
ComarExpo	http://www.comarexpo.com/index.php	New Bedford, USA	Engineering	Jun. 13 – 14 2012

3. ISMAR – CNR Web page

CNR ISMAR has prepared an internal website to share most of material collected, in particular visit reports and interview reports, as well as to concentrate any useful material and information which could help people to define the state of the art and latest improvements in fisheries:

http://www.ismar.cnr.it/projects/international-projects/project-001/iceef-en-en?set_language=en&cl=en

3.1 Topic specifications

In this section a short description of topic investigated is reported. The topic list created is useful to organize material collected and to show what kind of information could be found in material collected, specially in visit reports. Below the topic list:

- **Engines, fuels, biofuels, emissions, reduced environmental impacts, auxiliary power:**
New marine engine developments. New and efficient engines.
- **Vessel design and technology including, new hull systems, fishing boat design;**
New hull concepts and hydrodynamics new solutions related to propulsion systems
- **Propulsion systems, propellers:**
Propellers design and efficiency, performances and non conventional propellers developments.
- **Machinery**
Innovative system for auxiliary power and innovative machinery for energy saving such as electric and high efficiency deck machinery
- **Vessel hulls and engines maintenance;**
Hull cleaning and maintenance; Propeller cleaning; Engine controlling and maintenance
- **Use of alternative or renewable energy sources (wind, hydrogen fuel cells etc.);**
Power units applied onboard fishing vessels, renewable energy alternative non fossil fuel
- **Efficient fishing gears (e.g. reduced gear drag), selectivity;**
Fuel saving fishing gears Fishing gears with improved selectivity to reduce bycatch;
- **Fishing tactics and techniques, routing optimization;**
Course management; Fishing area monitoring and management;
- **Fuel management systems, energy monitoring and control systems, energy audits, other energy uses onboard;**
Monitoring systems for fuel consumption, energy usage, fishing gear geometrical characteristics and their advantages for energy saving and economic benefits

3.2 Visit and interview reports

During 2010 and 2011 many important events related to fishery technology were carried out. Important innovations were proposed and material collected has been studied and used to perform technical reports. Also international conferences were visited to define the state of the art of scientific improvements, which could create perspectives in short terms future for the definition of new technological applications.

Reports 2010

[Rep. 001 - Genoa Boat Show 2010](#)

[Rep. 002 - Innovation in Fisheries Areas](#)

[Rep. 003 - Workshop «Low impact dredges in Quebec»](#)

[Rep. 004 - Shanghai Symposium 2010](#)

[Rep. 005 - Energy Use in Fisheries](#)

[Rep. 006 - Pacific Marine Expo 2010](#)

[Rep. 007 - MondoPesca Expo 2010](#)

[Rep. 008 - Vicus dt](#)

[Rep. 009 - Van Beleen](#)

[Rep. 010 - HFK](#)

[Rep. 011 - Neill Jackson Trawl](#)

Reports 2011

[Rep. 001 - 71th International Fishing fair 2011](#)

[Rep. 002 - IMAM Conference 1 2011](#)

[Rep. 003 - IMAM Conference 2 2011](#)

[Rep. 004 - Icefish 2011](#)

[Rep. 005 - Danfish 2011](#)

[Rep. 006 - DeMaT Conference 2011](#)

[Rep. 007 - French Entities](#)

[Rep. 008 - Scottish Entities](#)

[Rep. 009 - USA Entities](#)

Interview reports

[Interview report 2010](#)

3.3 ICEEF Questionnaire

A questionnaire were created to investigate the point of view of the most important actors of fhishing industry were created. The questionnaire, accessible through the link <http://ticket.an.ismar.cnr.it/wp/?p=4>, creates an anonymous profile on the basis of some questions. Answers to the questions are collected via email and categorized in three major profiles: fishermen, stakeholder, other.

Questionnaire

who are you?

- Fisherman
- Stakeholder
- Other

What are your economic balance of the last ten years?

- At least the same
- Negative trend
- We are not profitable since ...

How can you save fuel?

- reducing fishing trip
- improving fishing gear efficiency
- improving propeller/propulsion system efficiency
- i have nothing to do for my vessel and equipment

Is the fuel consumption related to?

- fishing trip duration
- efficiency of the fishing vessel
- efficiency of the fishing gear
- efficiency of fishing tactics
- weather conditions
- other

What kind of help do you need, in your opinion, from the point of view of fuel saving?

- economical to confront costs
- technical to reduce fuel consumption
- political to improve rules and policy
- other

Which are the three main events that have concurred to create this situation?

- economical crisis
- rise up of fuel price
- fishing vessel is not efficient

Figure 55. ICEEF questionnaire

Depending on the results collected, further consideration could be performed and suggestions on which innovation achieves more interest by fishing industry actors are obtained.